

P



螺钉规格	P2~P6
插销规格	P7
垫片规格	P8~P12
刀夹规格	P12
压板组规格	P13~P14
压板规格	P15~P16
导屑器规格	P16
扳手规格	P17~P18
其他 零件规格	P18~P19
旧产品适用零件一览	P20~P37

螺钉规格

形状	型号	库存	尺寸(mm)						角度		扭矩(N·m)	备注
			A	B	C	D	E	F	α	θ		
	AJ -6X38	☉	M6X1.0	38.0	6.0	10.0	3.0	3.0	-	-	-	
	-8X44-9.5	☉	M8X1.25	44.0	9.5	6.0	4.0	4.0	-	-		
	-10X46	☉	M10X1.5	46.0	11.5	8.0	5.0	5.0	-	-		
	AJ -519TR	☉	M5X0.8	19.0	10.0	-	T15	-	-	40°	-	
	BH 3X6	☉	M3X0.5	6.0	-	2.0	2.0	-	-	-	-	
	3X12	☉	M3X0.5	12.0	-	2.0	2.0	-	-	-		
	6X25	☉	M6X1.0	25.0	-	4.0	4.0	-	-	-		
	BH 6X10TR	☉	M6X1.0	10.0	12.0	5.0	T25	-	-	-	6.5	
	CP 8X15TL	☉	M8X1.25	15.0	15.0	-	T25	-	-	-	6.0	L...左螺纹
	8X23TL	☉		23.0								
	CS -2D	☉	M4X0.7	21.5	6.4	3.5	2.5	2.0	-	-	1.7	
	-3D	☉	M5X0.8	22.0	8.0	4.0	3.0	2.5	-	-	3.9	
	-5D	☉	M5X0.8	28.0	8.0	4.0	3.0	2.5	-	-	3.0	
	CS -3D-TR	☉	M5X0.8	22.0	8.0	4.0	T15	T15	-	-	3.9	
	GS -50	☉	M5X0.8	13.0	7.5	-	3.0	-	-	82°	-	
	HF 20X53H	☉	M20X2.5	35.0	43.0	18.0	14.0	14.0	-	-	-	带冷却孔
	20X53HA	☉		33.0	50.0	20.0						
	24X60H	☉	M24X3.0	40.5	65.0	19.5	17.0					
	24X60HA	☉		36.0		24.0						
	HH 3X6	☉	M3X0.5	6.0	5.5	3.0	2.5	-	-	-		
	3X10S	☉		10.0	5.0							
	3X12	☉		12.0	5.5							
	HH 3.5X10S	☉	M3.5X0.6	10.0	5.5	3.0	2.5	-	-	-		
	HH 4X12S	☉	M4X0.7	12.0	7.0	4.0	3.0	-	-	-		
	4X16	☉		16.0								
	HH 5X12	☉	M5X0.8	12.0	8.5	5.0	4.0	-	-	-	L...左螺纹	
	5X15	☉		15.0								
	5X15L	☉		15.0								
	5X16	☉		16.0								
	5X20	☉		20.0								
	5X25	☉		25.0								
	5X30	☉		30.0								
	HH 6X12	☉		12.0								M6X1.0
	6X16	☉	16.0									
	6X16A	☉	16.0									
	6X18	☉	18.0									
	6X18A	☉	18.0									
	6X20	☉	20.0									
6X25	☉	25.0										
6X30	☉	30.0										
HH 8X20	☉	M8X1.25	20.0	13.0	8.0	6.0	-	-	-			
8X25	☉		25.0									

☉: 标准库存

P



零件

螺钉规格

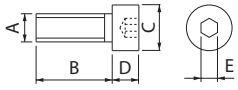
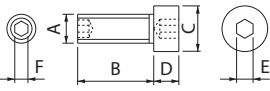
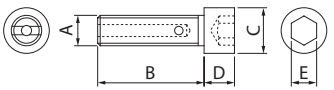
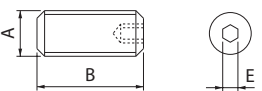
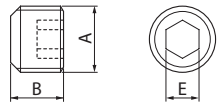
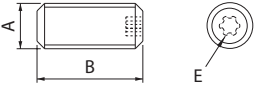
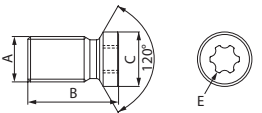
形状	型号	库存	尺寸(mm)					角度		扭矩(N·m)	备注		
			A	B	C	D	E	F	α			θ	
	HH 10X25	☉	M10X1.5	25.0	16.0	10.0	8.0	-	-	-	-		
	HH 10X30	☉		30.0									
	HH 10X30S	☉		30.0								6.0	7.0
	HH 10X35	☉		35.0									
	HH 10X40	☉		40.0								10.0	8.0
	HH 12X35	☉	M12X1.75	35.0	18.0	12.0	10.0	-	-	-			
	HH 12X40	☉		40.0									
	HH 16X35	☉	M16X2.0	35.0	24.0	16.0	14.0	-	-	-			
	HH 16X40	☉		40.0									
	HH 16X45	☉		45.0									
HH 20X40	☉	M20X2.5	40.0	30.0	20.0	17.0	-	-	-				
HH 20X55	☉		55.0										
	HH 4X12	☉	M4X0.7	10.0	7.0	4.0	3.0	2.0	-	-	-		
	HH 8X25H	☉	M8X1.25	25.0	13.0	8.0	5.0	-	-	-	-		
	HH 10X30H	☉	M10X1.5	30.0	16.0	10.0	6.0						
	HH 10X35HK	☉		35.0									
	HH 12X35H	☉	M12X1.75	35.0	18.0	12.0	8.0						
	HH 12X35HK	☉		35.0									
	HH 16X52H	☉	M16X2.0	36.0	24.0	16.0	12.0						
	HS 3X3P	☉	M3X0.5	2.9	-	-	1.5	-	-	-	1.0		
	HS 3X4P	☉		3.9									
	HS 3X4	☉		4.0									
	HS 4X4P	☉	M4X0.7	3.9	-	-	2.0	-	-	-	2.0		
	HS 4X4	☉		4.0									
	HS 5X5	☉	M5X0.8	5.0	-	-	2.5	-	-	-	3.0		
	HS 6X4P	☉	M6X1.0	3.9	-	-	3.0	-	-	-	4.0		
	HS 6X6	☉		6.0									
	HS 6X8T	☉		8.0									
	HS 6X14	☉		14.0									
	HS 6X22	☉		22.0									
	HS 8X10	☉	M8X1.25	10.0	-	-	4.0	-	-	-	-		
	HS 8X12	☉		12.0									
	HS 10X10	☉	M10X1.5	10.0	-	-	5.0	-	-	-	-		
	HS 10X16	☉		16.0									
	HS 12X12	☉	M12X1.75	12.0	-	-	6.0	-	-	-	-		
	HS 12X16	☉		16.0									
	HS 12X18	☉		18.0									
HS 12X20	☉	20.0											
HS 12X25	☉	25.0											
HS 12X30	☉	30.0											
HS 12X35	☉	35.0											
HS 16X12	☉	M16X2.0	12.0	-	-	8.0	-	-	-	-			
HS 16X18	☉		18.0										
HS 16X20	☉		20.0										
	HS 5X4LP	☉	M5X0.8	4.0	-	-	2.5	-	-	-	-		
	HS -2524TRP	☉	M2.5X0.35	2.4	-	-	5IP	-	-	-	0.5		
	HS -2534TRP	☉		3.4									
	HS -3048TRP	☉	M3X0.5	4.8								6IP	0.8
	HS -4067TRP	☉	M4X0.7	6.7								7IP	1.2
	HS -50100TRP	☉	M5X0.8	10	6.0	-	15IP	-	-	-	3.5		

☉: 标准库存



螺钉规格

形状	型号	库存	尺寸 (mm)						角度		扭矩 (N·m)	备注						
			A	B	C	D	E	F	α	θ								
	HSB 4x8 [°] L	☉	M4X0.7	8.0	R2.0	-	2.0	-	-	-	2.0	R...右螺纹 L...左螺纹						
	LS -03N	☉	M5X0.8	9.7	M5X0.8	-	2.0	-	-	-	2.0	带N的为镀银产品						
	LS -03SN	☉		12.0			2.5				3.0							
	LS -05	☉	M5X0.8	15.5	M5X0.8	-	2.0	2.0	-	-	2.0							
	LS -1N	☉	M6X1.0	17.0	6.0	-	2.5	2.5	-	-	3.0	带N的为镀银产品						
	LS -1SN	☉		14.2														
	LS -1T	☉		21.0														
	LS -2N	☉	M8X1.0	20.0	8.0	-	3.0	3.0	-	-	4.0							
	LS -3	☉	22.0															
	LS -4N	☉	24.0															
LS -5	☉	M10X1.0	29.0	10.0								-	4.0	4.0	-	-	-	
	LS -1P	☉	M6X1.0	16.5	6.0	-	10IP	10IP	-	-	2.0	○○IP为增强型扭矩						
	LS -2P	☉	M8X1.0	18.2	8.0		15IP	15IP			3.5							
	LS -3P	☉		21.8														
	LS -11	☉	M6X1.0	9.5	-	-	3.0	-	-	-	-							
	LS -15	☉		12.5														
	M 3X8	☉	M3X0.5	8.0	5.5	2.0	-	-	-	-	-	相当于JIS...B-1101的平头小螺钉						
	M 3X12	☉		12.0														
	M 4X10	☉		M4X0.7									10.0	7.0	2.6			
	SB -1TR	☉	M2X0.4	5.3	3.8	-	-	T6	-	82°	0.5	R...右螺纹						
	SB -2TR	☉	M2.5X0.45	6.2	4.5			T8			1.2							
	SB -3TR	☉	M3X0.5	7.2	4.8			T10			2.0							
	SB -3STR	☉		6.4	5.2													
	SB -3.5TR	☉	M3.5X0.6	9.3	5.6			T15			3.5							
	SB -4TR	☉	M4X0.7	7.7	5.8			T20			90°		4.5					
	SB -5TR	☉	M5X0.8	20.0	8.7													
	SB -2290TR	☉	M2.2X0.45	9.2	2.8								T6	0.5				
	SB -25100TR	☉	M2.5X0.45	10.0	3.5			T7			0.8							
	SB -40115TR	☉	M4X0.7	11.5	5.5			T15			3.5							
	SB -5070TR	☉	M5X0.8	7.0	6.8			T20			60°		4.5					
	SB -5090TR	☉		9.0														
	SB -50120TR	☉		12.0														
		SB -1STR	☉	M2X0.4	5.0			3.1			-		-	T6	-	60°	0.5	R...右螺纹 L...左螺纹
		SB -1635TR	☉	M1.6X0.35	3.3			2.6						6IP				
SB -1840TRP		☉	M1.8X0.35	4.0	2.5	T6	60°											
SB -2035TR		☉	M2X0.4	3.7	3.0													
SB -2035TRG		☉		3.5	2.7	6IP	55°											
SB -2037TRP		☉		3.7														
SB -2040TR		☉	3.8	3.0	T6	60°												
SB -2040TRG		☉	4.0															
SB -2041TRP		☉	4.1	2.7	6IP	60°												
SB -2042TRG		☉	4.3															
SB -2045TR		☉	4.3	2.8	T6	37°												
SB -2045TRN		☉	4.8	3.0														
SB -2050TR		☉	5.8	3.5	T8	60°	1.2											
SB -2060TR		☉	8.3	2.8	T6	0.5												

☉: 标准库存

P



零件

螺钉规格

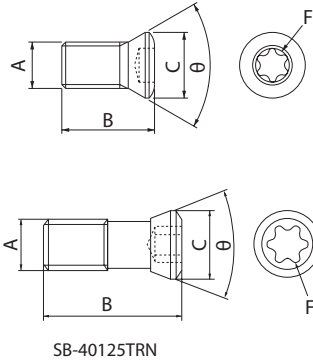
形状	型号	库存	尺寸 (mm)						角度		扭矩 (N·m)	备注			
			A	B	C	D	E	F	α	θ					
 <p>SB-40125TRN</p>	SB -2250TR	☉	M2.2X0.45	5.1	3.1	-	-	T7	-	60°	0.8	R...右螺纹 L...左螺纹 ○○IP为增强型扭矩			
	SB -2255TR	☉		5.5	3.5										
	SB -2260TR	☉		5.8	3.1										
	SB -2270T ^{PH} L	☉		6.8	3.2										
	SB -2545TR	☉	M2.5X0.45	4.6	3.5	-	-	T8	-	60°	1.2				
	SB -2555TRG	☉		5.4											
	SB -2555TRP	☉		5.5				8IP							
	SB -2560TR	☉		5.7				T8							
	SB -2570TR	☉		6.8											
	SB -3060TR	☉	M3X0.5	5.3	4.0	-	-	T10	-	60°	2.0				
	SB -3060TRP	☉		6.0				10IP			1.2				
	SB -3065TRP	☉		6.5				8IP			2.0				
	SB -3070TRG	☉		4.2				T10			1.2				
	SB -3070T ^{PH} L	☉		7.0				4.0			T8		2.0		
	SB -3070TRP	☉		4.2				10IP			2.0				
	SB -3076TRP	☉		7.6				3.9			55°		2.0		
	SB -3080TR	☉		8.0				4.2			60°				
	SB -3573TRP	☉	M3.5X0.6	7.3	5.0	-	-	10IP	-	60°	2.0				
	SB -3575TRP	☉		7.5	4.9			T15			3.5				
	SB -3580TR	☉		8.0	5.3			15IP			4.0				
	SB -3590TRP	☉		9.0				T10			2.0				
	SB -3592TR	☉		9.2	5.1			15IP			4.0				
	SB -35120TRP	☉		12.0	5.2										
	SB -4050TRN	☉	M4X0.5	4.6	5.1	-	-	T10	-	57°	2.0				
	SB -4060TR	☉	M4X0.7	5.9	5.5			T15		60°	3.5				
	SB -4065TR	☉		6.7				T10			2.0				
	SB -4070TRG	☉		7.0				15IP			3.5				
	SB -4070TRN	☉		7.7				5.4					T15		
	SB -4070TRS	☉		6.7									15IP		
	SB -4075TRP	☉		7.5									T15		
	SB -4082TPR	☉		8.2									15IP		
	SB -4085TR	☉		8.5									T15		
	SB -4085TRP	☉		8.6									15IP		
	SB -4090TRP	☉		9.0				5.7					T15	50°	4.5
	SB -4090TRPS	☉						5.5							
	SB -4090TRPN	☉						5.5							
	SB -40104TRP	☉						10.4			5.7				
	SB -40120TR	☉		12.0				5.1			60°		4.5		
	SB -40125TRN	☉	12.5	5.2											
	SB -40140TR	☉	14.0	5.5											
SB -40140TRN	☉	6.7	75°												
SB -44865UTRP	☉	UNF No.4-48	6.5	3.8	-			-		8IP	-	60°	1.2		
SB -44880UTRP	☉		8.0												
SB -4570TRN	☉	M4.5X0.5	6.8	6.0	-	-	T10	-	57°	2.0					
SB -45130TR	☉	M4.5X0.75	13.0	6.6			20IP		55°	4.5					
SB -5085TR	☉	M5X0.8	8.5	6.8	-	-	T20	-	50°	4.5					
SB -50110TRP	☉		11.0	7.0			20IP		60°						
SB -50120TRP	☉		12.0	6.8			15IP		3.5						
SB -50120TRPH	☉						7.2								
SB -50120TRS	☉		13.7	9.7			T20		70°		4.5				
SB -50137K	☉		14.0	7.3			T15		50°		4.2				
SB -50140TR	☉						20IP		60°		4.5				
SB -50140TRP	☉														
SB -50140TRPS	☉														
SB -60120TR	☉		M6X1.0	12.0			8.5		-		-	T25	-	60°	6.0
SB -60130TRP	☉	13.0		20IP	4.5										
SB -60200TRP	☉	20.0			6.0										
SB -4070TRW	☉	M4X0.7	6.7	5.5	-	-	T8	-	60°	1.2					
SB -4590TRWN	☉	M4.5X0.75	9.3	5.6			T10		57°	2.0					

☉: 标准库存

参考

普通扭矩与增强型扭矩的断面形状不同。



普通扭矩



增强型扭矩



零件

螺钉规格

形状	型号	库存	尺寸(mm)						角度		扭矩(N-m)	备注		
			A	B	C	D	E	F	α	θ				
	SC	-30067	⊙	M3X0.35	6.7	4.4				T8	60°	1.2		
		-35085	⊙	M3.5X0.35	8.5	5.7				T10		2.0		
		-40100	⊙	M4X0.5	10.0	6.0				T15		3.5		
		-50130	⊙	M5X0.5	13.0	6.6	-	-		T20	40°	4.5		
		-60160	⊙	M6X0.75	16.0	8.0				T25		6.0		
		-60210	⊙	M6X0.75	21.0	9.6				T30		8.0		
	SE	-3070TRP	⊙	M3X0.5	7.0	4.3				9IP	43°	1.7	⊙IP为增强型扭矩	
		-40050TRN	⊙		5.0									
		-40055TR	⊙		5.5									
		-40068TR	⊙	M4X0.7	6.8	5.0	-	-		T15	44°	3.5		
		-40080TR	⊙		8.0									
		-40090TR	⊙		9.0									
		-40100TR	⊙		10.0									
	SE	-40120TR	⊙	M4X0.7	12.0	5.6				T15	60°	3.5		
		-50125TR	⊙	M5X0.8	12.5	6.8				T20		4.5		
	SH	-50150TR	⊙	M5X0.8	15.1	7.3	3.1	-	-	T20	-	4.5		
	SP	3X4	⊙	M3X0.5	4.0	4.0					90°	-	下述平头小螺钉的 追加工品 相当于JIS...B-1111 带2号孔十字平头小螺钉	
		3X6	⊙		6.0									
		3X8	⊙		8.0	6.0								
		3X10	⊙		10.0									
	SP	4X9	⊙	M4X0.7	9.0	5.6		2.0	-	-	90°	-		
	SP	8X35	⊙	M8X1.25	35.0	11.0	4.4	5.0	-	-	90°	-		
	SPW	-5035	⊙	M5X0.5	7.0	6.3	M3.5X0.6	3.5					A为外螺纹、 D为内螺纹 外螺纹、内螺纹的加工 皆为右螺纹	
		-6045	⊙	M6X0.75	9.0	7.5	M4.5X0.75	4.5						
		-7050	⊙	M7X0.75	9.0	8.8	M5X0.8	5.0						
		SS	-4N	⊙	M5.5X0.5	8.5	6.6	M4X0.7	4.0					
	SV	-60136R	⊙	M6X1.0	13.6	6.3				T25	6°	-	普通扭矩规格	
		-60136TR	⊙									T20		
	TH	8X15	⊙	M8X1.25	20.0	8.5		4.0	-	-	-	-		
	W	6X17	⊙	M6X1.0	17.0					T20	-	4.5		
		6X18N	⊙		18.0						T15	-		3.5
		8X16	⊙		M8X1.0	16.0					T25	-		6.0
	W	6X18	⊙	M6X1.0	17.5									
		6X20	⊙	M6X1.0	20.5			3.0						
		8X18	⊙	M8X1.25	18.0									
		*8X21	⊙	M8X1.0	21.0				4.0					
	W	10X31	⊙	M10X1.0	31.0	M10X1.5		5.0	-	-	-	-		

* 单孔规格(右螺钉位置无扳手孔)

⊙: 标准库存

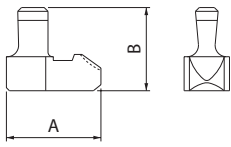
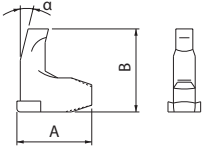
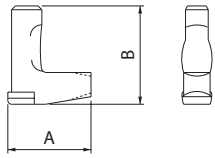
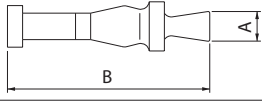
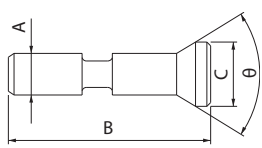
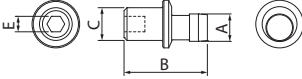
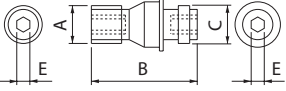
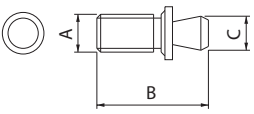
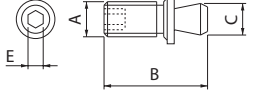
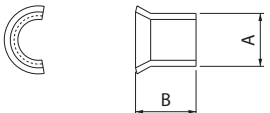
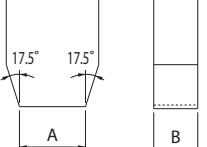

插销规格

形状	型号	库存	尺寸 (mm)						角度		备注
			A	B	C	D	E	F	α	θ	
	LL -03N	☉	7.8	6.3							
	LL -03SN	☉	11.1	8.9	-	-	-	-	-	-	
	LL -03TN	☉	8.3	8.9							
	LL -05C	☉	10.7	11.7					12°		
	LL -1CN	☉	13.0	13.3	-	-	-	-	14°	-	
	LL -2C	☉	18.8	17.6					14°		
	LL -1K	☉	10.0	12.0							
	LL -1N	☉	10.3	12.0							
	LL -1DN	☉	12.3	12.0							
	LL -2K	☉	13.3	13.2							
	LL -2N	☉	13.5	13.0							
	LL -3K	☉	16.0	14.8							
	LL -3N	☉	16.4	13.0							
	LL -4N	☉	16.4	14.7							
	LL -5N	☉	17.1	16.7							
LL -6	☉	20.7	21.0								
	LP -2S	☉	3.65	20.0	-	-	-	-	-	-	
	LP -6S	☉	3.65	25.0	-	-	-	-	-	-	
	LPA -11	☉		11.0							
	LPA -13	☉	2.8	13.0	4.2	-	-	-	-	60°	
	LPA -17	☉		17.0							
	LPF -11	☉		11.0							
	LPF -1113	☉	2.5	13.0	3.5	-	-	-	-	60°	
	LPF -1117	☉		17.0							
	LPF -13	☉	3.8	13.0	5.5	-	-	-	-		
LPF -17	☉		17.0								
	PP -4	☉	4.6	14.0	5.5	-	3.0	-	-	-	
	TS -3S	☉	M5X0.8	15.0	3.60	-	2.0	-	-	-	
	WP -1S	☉	M5X0.8	18.0	3.65	-	-	-	-	-	
	WP 5X15	☉		15.0	5.0						
	WP 5X11	☉	M5X0.8	10.5	5.0	-	2.0	-	-	-	
	LSP -1	☉	5.0	5.3							
	LSP -2	☉	6.5	5.6							
	LSP -3	☉	8.25	7.9							
	LSP -4	☉	9.5	10.0							
	LSP -2K	☉	5.1	5.2							
LSP -3K	☉	6.7	5.7								
	P -03	☉	2.8	1.95	-	-	-	-	-	-	
	P -03S	☉	3.5	1.95	-	-	-	-	-	-	

☉: 标准库存



垫片规格

形状 有方向时图示右手 (R)	型号	库存	尺寸 (mm)						角度		备注
			A	B	C	D	E	F	α	θ	
	DC -42	☉	12.0	3.2	1.2	6.0	4.4	R1.2	-	-	垫片紧固螺钉： SB-4085TR
	-44	☉	12.55	5.0	1.5			R0.8			
	DC -44-C	☉	12.55	5.0	1.5	6.0	4.4	-	-	-	垫片紧固螺钉： SB-4085TR
	DD -42	☉	12.55	3.2	1.2	6.0	4.4	R1.2	-	-	垫片紧固螺钉： SB-4085TR
	-42-16	☉						R1.6			
	-43	☉		3.4	1.3			R0.8			
	-44	☉		5.0	1.5			R0.8			
	DS -42	☉	12.0	3.2	1.2	6.0	4.4	R1.2	-	-	垫片紧固螺钉： SB-4085TR
	-44	☉	12.55	5.0	1.5			R0.8			
	DT -32	☉	8.63	3.2	0.95	5.0	3.4	R1.6	3°	-	垫片紧固螺钉： SB-3080TR
	-42	☉	12.46		1.2			6.0	4.4	R1.2	-
	DV -33	☉	9.40	3.5	1.2	6.0	4.4	R1.0	-	-	垫片紧固螺钉： SB-4085TR
	DW -42	☉	11.5	3.2	1.2	6.0	4.4	R1.2	4°	-	垫片紧固螺钉： SB-4085TR
	-44	☉	12.65	5.0	1.5			R0.8	-		
	556 C [°] /L	☉	34.0	10.0	12.7	5.6	5.0	R1.6	0°	55°	R...右手, L...左手 垫片紧固螺钉： HH5X16
	KPS -42	☉	11.5	3.2	2.0	7.2	3.2	C1.0	7°	-	垫片紧固螺钉：SP3X8
	KPT -32	☉	8.0	3.2	1.9	7.0	3.2	R0.4	11°	-	垫片紧固螺钉：SP3X8 SP3X10
	-42	☉	10.5	3.2	1.9	7.0	3.2	R0.8	11°	-	
	KVN -32	☉	9.52	3.2	2.1	7.6	5.5	R0.8	-	-	紧固插销：LP-2S LP-6S
	LC -32N	☉	9.47	2.4	1.3	6.18	4.68	R0.8	-	-	金属销：LSP-1
	-4K	☉	11.7	3.2	1.4	8.1	6.73	R0.8	-	-	金属销：LSP-3K
	-42N	☉	12.65	3.2	1.5	8.01	6.28	R0.8	-	-	金属销：LSP-2
	-42N-20	☉						R2.0			
	-53N	☉	15.9	4.8	1.7	10.0	8.0	R1.2	-	-	金属销：LSP-3
	-63	☉	19.0	4.8	2.0	11.61	9.3	R1.6	-	-	金属销：LSP-4

☉：标准库存

垫片规格

形状 有方向时图示右手 (R)	型号	库存	尺寸 (mm)							角度		备注
			A	B	C	D	E	F	α	θ		
	LC -42N-C	☉	12.65	3.2	1.5	8.01	6.28	-	-	-	金属销：LSP-2	
	LC -53N-C	☉	15.9	4.8	1.7	10.0	8.0	-	-	-	金属销：LSP-3	
	LC -63-C	☉	19.0	4.8	2.0	11.61	9.3	-	-	-	金属销：LSP-4	
	LC -42N ⁹ L	☉	12.65	3.2	1.5	8.01	6.28	R0.8	10°	-	R...右手, L...左手 金属销：LSP-2	
	LD -32N	☉	9.47	2.4	1.3	6.18	4.68	R0.8	-	-	金属销：LSP-1	
	LD -4K	☉	11.7	3.2	1.4	8.1	6.73	R0.8	-	-	金属销：LSP-3K	
	LD -4K43	☉		4.8	3.0	8.3	6.60	R1.2	-	-	金属销：LSP-2	
	LD -42	☉	12.65	3.2	1.5	8.01	6.28	R0.8	-	-		
	LD -42-20	☉	12.65	4.8	3.1	8.5	6.28	R2.0	-	-		
	LD -43	☉						R0.8	-	-		
LD -43-20	☉						R2.0	-	-			
	LR -80	☉	9.47	3.2	1.3	6.25	4.75	-	-	-	金属销：LSP-1	
	LR -81	☉	12.65	3.2	1.5	8.01	6.28	-	-	-	金属销：LSP-2	
	LR -10C	☉	8.5	3.2	6.3	6.3	4.7	-	-	-	金属销：LSP-1	
	LR -12C	☉	10.0	3.2	6.3	6.3	4.7	-	-	-	金属销：LSP-2	
	LR -16C	☉	13.6	3.2	7.9	8.01	6.28	-	-	-		
	LS -32	☉	9.47	3.2	1.3	6.18	4.68	R0.8	-	-	金属销：LSP-1	
	LS -42	☉	12.65	3.2	1.5	8.01	6.28	R0.8	-	-	金属销：LSP-2	
	LT -3K	☉	8.53	2.7	1.0	6.1	5.13	R0.8	-	-	金属销：LSP-2K	
	LT -32N	☉	9.47	2.7	1.3	6.18	4.68	R0.8	-	-	金属销：LSP-1	
	LT -32N-20	☉						R2.0	-	-		
	LT -42N	☉	12.65	3.2	1.5	8.01	6.28	R0.8	-	-	金属销：LSP-2	
LT -42N-20	☉	R2.0						-	-			
	LW -32N	☉	9.47	2.4	1.3	6.18	4.68	R0.8	-	-	金属销：LSP-1	
	LW -42N	☉	12.65	3.2	1.5	8.01	6.28	R0.8	-	-	金属销：LSP-2	
	LW -42N ⁹ L	☉	12.65	3.2	1.5	8.01	6.28	R0.8	10°	-	R...右手, L...左手 金属销：LSP-2	
	MFPN -45	☉	17.07	3.5	1.95	9.8	7.18	R3.5	-	-	垫片螺钉： SPW-7050	
	MFSE -105	☉	10.5	3.0	1.4	7.0	5.3	-	7°	45°	垫片螺钉： SPW-5035	
	MFWN -90	☉	15.25	4.0	2.5	9.44	7.25	R3.0 R4.0	-	-	垫片螺钉： SPW-7050	
	MSD -42	☉	10.7	3.2	1.85	7.0	3.3	-	20°	45°	垫片紧固螺钉：SP3X8	
	MSE -4245S	☉	10.3	3.2	2.0	6.0	5.0	-	20°	45°	垫片紧固螺钉：SP4X9	
	MSE -4215	☉	10.53	3.2	1.5	6.4	3.4	-	25°	15°	垫片紧固螺钉：SP3X8	
	MSE -4245	☉	10.53	3.2	1.5	6.4	3.4	-	25°	45°	垫片紧固螺钉：SP3X8	

☉: 标准库存



件

垫片规格

形状	型号	库存	尺寸(mm)							角度		备注
			A	B	C	D	E	F	α	θ		
	MSO -4T245	●	10.0	2.0	4.7	6.4	4.8	-	27°	45°	垫片紧固螺钉：SP3X6	
	MSO -5200	●	12.6	3.18	1.8	8.27	6.66	R0.8	15°	-	垫片紧固螺钉：SPW-6045	
	MSP -42	●	11.3	3.2	1.85	7.0	3.3	-	15°	15°	垫片紧固螺钉：SP3X8	
	MTE -42	●	9.8	3.2	-	6.4	3.4	-	25°	-	垫片紧固螺钉：SP3X8	
	MVN -32	●	9.52	3.2	2.1	7.4	6.5	R0.8	-	-	紧固插销：TS-3S	
	PD -42	●	12.7	3.2	1.7	6.0	8.4	0.8	12°	-	垫片紧固螺钉：SB-2050TR	
	SP -129	●	9.52	9.52	R0.8	R1.6	R1.2	R1.6	-	-	垫片紧固螺钉：HH3X12	
	SP -141	●	12.7	4.0	2.4	6.2	3.3	R1.2	-	-	垫片紧固螺钉：M3X8	
	-143	●	12.7	7.2	2.4	6.2	3.3	R1.2	-	-	垫片紧固螺钉：M3X12	
	-162	●	15.8	6.0	3.4	8.0	4.4	R1.5	-	-	垫片紧固螺钉：M4X10	
	SP -148	●	12.7	8.8	2.4	6.2	3.3	R1.2	-	-	垫片紧固螺钉：BH3X12	
	SP -219	●	6.35	9.52	R0.8	R1.2	R1.6	-	-	-	垫片紧固螺钉：HH3X12	
	SP -221	●	9.52	4.0	2.5	6.5	3.5	R1.2	-	-	垫片紧固螺钉：M3X8	
	-223	●	9.52	7.2	2.5	6.5	3.5	R1.2	-	-	垫片紧固螺钉：M3X12	
	SP -342	●	12.7	6.0	2.5	6.5	3.5	R1.2	-	75°	垫片紧固螺钉：M3X8	
	-441	●	12.7	4.0	2.5	6.2	3.3	R0.8	-	80°	垫片紧固螺钉：M3X8	
	-443	●	12.7	7.2	2.5	6.2	3.3	R0.8	-	80°	垫片紧固螺钉：M3X12	
-454	●	15.7	8.0	3.4	8.0	4.5	R1.6	-	80°	垫片紧固螺钉：M4X10		

●: 标准库存

垫片规格

形状	型号	库存	尺寸 (mm)						角度		备注
			A	B	C	D	E	F	α	θ	
	SP -429	☉	9.52	9.52	-	-	-	R1.2	-	-	垫片紧固螺钉： HH3X12
	SP -521	☉	10.0	4.0	2.5	6.2	3.3	R1.0	-	-	垫片紧固螺钉：M3X8
	-523	☉		7.2							垫片紧固螺钉：M3X12
	-541	☉	12.7	4.0	2.5	6.2	3.3	R1.2	-	-	垫片紧固螺钉：M3X8
	-543	☉		7.2							垫片紧固螺钉：M3X12
	SP -826	☉	9.52	7.9	-	-	-	-	-	-	垫片紧固螺钉： HH3X12
	-829	☉	9.52	9.52	-	-	-	-	-	-	
	SP -841	☉	12.7	4.0	2.4	6.2	3.3	-	-	-	垫片紧固螺钉：M3X8
	-843	☉	12.7	7.2	2.4	6.2	3.3	-	-	-	垫片紧固螺钉：M3X12
	-849	☉	12.7	8.8	2.4	6.2	3.3	-	-	-	垫片紧固螺钉：BH3X12
	-861	☉	15.8	6.0	3.4	8.0	4.4	-	-	-	垫片紧固螺钉：M4X10
	SP -130A	☉	9.52	3.2	-	R0.4	R0.8	R1.2	8°	-	垫片紧固螺钉：BH3X12
	SP -210A	☉	6.35	3.2	R0.4	R0.8	R1.2	-	8°	-	垫片紧固螺钉：BH3X6
	SP -420A	☉	9.52	3.2	-	-	R0.8	R1.2	8°	-	垫片紧固螺钉：BH3X6
	SP -141P	☉	12.7	4.0	2.4	6.2	3.3	R1.2	7°	-	垫片紧固螺钉：M3X8
	-143P	☉	12.7	7.2	2.4	6.2	3.3	R1.2	7°	-	垫片紧固螺钉：M3X12
	SP -230P	☉	8.3	3.2	2.0	7.2	3.2	R0.5	7°	-	垫片紧固螺钉： SP3X10
	SP -341P	☉	12.6	4.0	2.5	6.5	3.5	R1.2	7°	-	垫片紧固螺钉：M3X8
	SP -441P	☉	12.7	4.0	2.5	6.2	3.3	R1.2	11°	-	垫片紧固螺钉：M3X8
	-443P	☉		7.2							垫片紧固螺钉：M3X12
	SP -521P	☉	10.0	4.0	2.5	6.2	3.3	R1.2	11°	-	垫片紧固螺钉：M3X8
	-523P	☉		7.2							垫片紧固螺钉：M3X12

☉: 标准库存



垫片规格 · 刀夹规格

形状 有方向时图示右手 (R)	型号	库存	尺寸 (mm)						角度		备注
			A	B	C	D	E	F	α	θ	
	SP -RC	☉	12.6	3.0	-	7.35	3.35	-	-	-	垫片紧固螺钉：SP3X8
	SVN -32	☉	8.0	3.2	1.5	3.1	2.3	R0.4	-	-	垫片紧固螺钉： SB-2050TR
	SVN -32N	☉	8.2	3.2	1.5	7.0	5.9	R0.6	-	-	垫片紧固螺钉： SS-4N
	SVN -32S	☉	8.2	3.2	1.5	7.0	5.9	R0.2	-	-	垫片紧固螺钉： SS-4N 1刀尖规格
	TN -32	☉	9.52	3.2	6.5	7.0	4.2	R0.4	-	-	垫片紧固螺钉：SP3X8
	-43	☉	12.70	3.2	8.1	7.0	4.2	R0.5	-	-	
	TNW -32	☉	9.52	3.2	4.8	7.0	4.2	-	-	-	垫片紧固螺钉：SP3X8
	WTN -33	☉	9.52	4.76	2.5	7.0	5.3	R0.8	-	-	金属销：WP-1S
	-33-20	☉						R2.0			
	WWN -42	☉	12.7	3.0	1.4	7.0	5.3	R1.2	-	-	金属销：WP5X15
	WWP -42	☉	12.7	3.0	1.5	8.3	5.3	R1.2	11°	-	金属销：WP5X11
	-42-16	☉						R1.6			
	MAP -2216	☉	-	9.0	11.0	19.8	-	-	20°	-	紧固螺钉： SB-40140TR
	MAP -2506	☉	-	9.5	14.9	20	-	-	5°	-	紧固螺钉： SB-40140TR
	LSE -445R	☉	12.7	13.0	19.5	26.0	-	-	20°	45°	A表示使用刀片的 内接圆径
	LSO -445R	☉	13.494	12.0	21.3	23.5	-	-	27°	45°	

☉: 标准库存

P

零件

压板组规格

形状 有方向时图示右手 (R)	型号	库存	尺寸 (mm)							备注
			A	B	C	D	E	F	G	
	BCS -1	☉	64.0	13.0	-	-	-	-	-	
	-5	☉	48.0	16.5	-	-	-	-	-	
	BCS -2	☉	74.0	15.0	-	-	-	-	-	
	-3	☉	88.0	16.0	-	-	-	-	-	
	BCS -4	☉	98.0	16.0	-	-	-	-	-	
	CE -010	☉	M8X1.25	28.0	24.0	12.8	13.0	4.0	4.0	G: 螺栓内侧 六角孔的2面宽度
	-220	☉			27.0	15.8	15.0			
	CE -020	☉	M8X1.25	30.0	17.0	10.5	12.7	4.0	4.0	G: 螺栓内侧 六角孔的2面宽度
	CE -030	☉	M8X1.25	30.0	19.0	12.5	12.7	4.0	4.0	G: 螺栓内侧 六角孔的2面宽度
	-040	☉			22.5	16.0				
	CE -320	☉	M6X1.0	24.5	18.2	9.7	12.7	4.0	-	
	CE -360S	☉	M6X1.0	16.0	18.0	10.55	12.4	4.0	-	
	CE -030A	☉	M8X1.25	30.0	20.0	13.7	12.7	4.0	-	G: 螺栓内侧 六角孔的2面宽度
	CE -410	☉	M8X1.25	30.0	26.0	19.5	12.7	4.0	4.0	G: 螺栓内侧 六角孔的2面宽度
	-430	☉			29.0	22.5				
	CP -RC^Y/L	☉	M6X1.0	20.0	24.5	14.8	11.0	5.0	-	R...右手, L...左手

☉: 标准库存



件
号

压板组规格

形状 有方向时图示右手 (R)	型号	库存	尺寸 (mm)							备注
			A	B	C	D	E	F	G	
	CPS -1	☉	M3X0.5	9.0	10.0	5.2	5.5	2.0	-	
	CPS -2	☉	M5X0.8	14.5	14.0	8.5	6.8	2.5	2.5	G: 螺栓内侧 六角孔的2面宽度
	-2P	☉		18.0						
	-3	☉	M6X1.0	19.0	16.5	10.0	8.8	3.0	3.0	
	CPS -2S	☉	M5X0.8	13.5	14.0	8.5	6.8	T15	2.0	G: 螺栓内侧 六角孔的2面宽度
	-2TR	☉		15.0						
	CPS -4V	☉	M4X0.7	8.9	11.3	7.3	8.0	T10	-	G: 螺栓内侧 六角孔的2面宽度
	-5F	☉	M5X0.8	11.3	12.7	7.5	10.3	T15	2.5	
	-5S	☉		18.0	15.0	9.5	11.0		2.0	
	-5V	☉		13.5	12.7	7.5	10.3		2.5	
	CPS -6F	☉	M6X1.0	16.5	15.6	9.5	12.2	3.0	-	G: 螺栓内侧 六角孔的2面宽度
	-6M	☉		18.5	17.5	11.0	13.0			
	-6S	☉			18.0	12.0	12.0			
	-6V	☉			15.6	9.5	12.2			
	-8V	☉	M8X1.25	24.0	20.8	13.0	15.5	4.0	4.0	
	CPS -5E	☉	M5X0.8	13.5	17.5	12.0	9.0	T15	2.5	G: 螺栓内侧 六角孔的2面宽度
	CPS -5 ^{R/L}	☉	M5X0.8	18.0	17.5	12.0	9.0	2.5	2.5	G: 螺栓内侧 六角孔的2面宽度 R...右螺纹, L...左螺纹
	LGBA -16 ^{R/L}	☉	M5X0.8	15.0	16.1	11.2	9.85	T15	2.0	G: 螺栓内侧 六角孔的2面宽度 R...右手, L...左手
	-22 ^{R/L}	☉			17.6	12.7				
	WCS -1N	☉	M6X1.0	21.0	15.7	-	15.0	3.0	-	
	WCS -8	☉	M6X1.0	21.0	19.4	-	15.0	3.0	-	

☉: 标准库存



压板规格

形状 有方向时图示右手 (R)	型号	库存	尺寸 (mm)						角度		备注
			A	B	C	D	E	F	α	θ	
	C 08R	☉	7.6	8.7	8.9	3.6	M5X0.8 (左螺纹)	-	10°	-	
	C 09N	☉	6.0	9.0	9.8	5.3	M6X1.0 (左螺纹)	-	10°	-	紧固螺钉: W6X18N
	C 17R	☉	12.2	20.0	14.3	8.5	M8X1.25 (左螺纹)	-	12°	-	紧固螺钉: W8X18
	C 20R	☉	15.1	15.5	15.0	7.5	5.3	-	10°	-	紧固螺钉: TH8X15
	CH -20R	☉	13.1	15.5	14.8	7.5	5.3	-	10°	-	紧固螺钉: TH8X15
	C 25R	☉	13.2	15.5	15.0	7.5	5.3	-	10°	-	紧固螺钉: TH8X15
	CGA -3 ^{R/L}	☉	24.0	17.66	12.0	6.2	1.9	11.0	-	-	R...右手, L...左手
	-4 ^{R/L}	☉	24.0	17.66	12.0	6.2	2.9	11.0	-	-	
	-5 ^{R/L}	☉	27.5	18.66	12.0	6.2	3.9	14.5	-	-	
	CGB ^{R/L}	☉	19.0	14.0	8.2	6.35	9.5	-	-	-	R...右手, L...左手
	CGH -1 ^{R/L}	☉	25.0	22.0	8.0	6.05	3.0	5.5	-	-	R...右手, L...左手
	-2 ^{R/L}	☉					5.0				
	-3 ^{R/L}	☉	30.0	23.0	8.5		6.0	7.0			
	CGIA -3R	☉	10.7	17.0	10.5	5.2	1.8	2.0	-	-	
	-4R	☉			11.5		2.5				
	-5R	☉	15.7		10.5		3.5	7.0			

☉: 标准库存



件
号

压板·导屑器规格

形状 有方向时图示右手 (R)	型号	库存	尺寸 (mm)						角度		备注
			A	B	C	D	E	F	α	θ	
	CP -2D	☉		10.0	21.6		10.4				
	CP -3D	☉	-	12.0	27.6	-	14.0	-	-	-	
	CP -5D	☉		13.0	32.0						
	CP -2D-R/L-JCT	☉	-	13.5	25.3	-	21.5	-	-	-	
	CP -3D-R/L-JCT	☉			26.4		17.9				
	CP -4D-R/L-JCT	☉	-	13.1	28.4	-	18.2	-	-	-	
	CP -5D-JCT	☉			31.9		21.5				
	CP -8TE	☉	17.9	12.0	12.0	M8X1.25 (左螺纹)	10.0	-	15°	-	
	CP -8W	☉	20.9	12.0	8.0	M8X1.25 (左螺纹)	13.0	-	3°	-	
	CB -11	☉	11.5	12.7	3.5	-	-	-	-	-	
	CB -51	☉	16.0	15.6	3.5	-	-	-	-	-	
	CB -12	☉	14.0	12.7	3.5	-	-	-	-	右手	
	CB -13	☉	14.0	12.7	3.5	-	-	-	-	左手	
	CB -14	☉	18.51	12.7	3.5	-	-	-	-	右手	
	CB -15	☉	18.51	12.7	3.5	-	-	-	-	左手	
	CB -16	☉	18.0	12.7	3.5	-	-	-	-		
	CB -17	☉	21.0	15.6	3.5	-	-	-	-		
	CB -S3220	☉	7.94	7.94	1.0	2.0	-	-	-		
	CB -S4220	☉	11.12	11.12	2.0	2.0	-	-	-		
	CB -T2212	☉	7.48	-	1.5	1.2	-	-	-		
	CB -T3220	☉	10.87	-	2.0	2.0	-	-	-		

☉: 标准库存

扳手规格

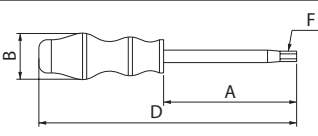
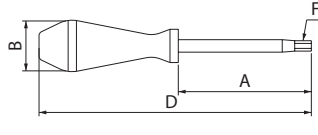
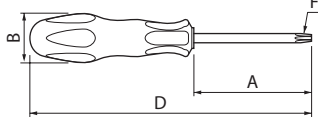
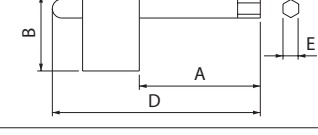
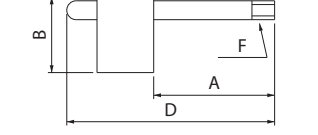
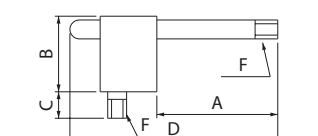
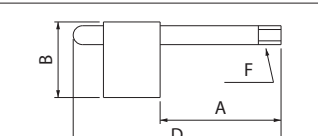
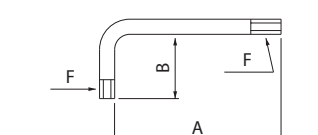
形状	型号	库存	尺寸(mm)						角度		备注	
			A	B	C	D	E	F	α	θ		
	DT -7	☉	44	16	-	114	-	T7	-	-	普通扭矩	
	-8	☉	70	26	-	150	-	T8	-	-		
	DT -10	☉	70	29	-	160	-	T10	-	-	普通扭矩	
	-15	☉	70	32	-	170	-	T15	-	-		
	-20	☉	90	32	-	190	-	T20	-	-		
	-25	☉	82	36	-	190	-	T25	-	-		
	DTM -6	☉	40	17	-	115	-	T6	-	-	普通扭矩 顶部磁化	
	-7	☉	44	17	-	119	-	T7	-	-		
	-8	☉	70	24	-	150	-	T8	-	-		
	-10	☉	70	28	-	167	-	T10	-	-		
	-15	☉	70	31	-	174	-	T15	-	-		
	DTP -6	☉	73	23	-	150	-	6IP	-	-	☉IP为增强型扭矩	
	-7	☉						7IP				
	-9	☉	61	30				174				9IP
	-15	☉	81	33				186				15IP
	-20	☉	100					206				20IP
DTPM -8	☉	70	24	-	150	-	8IP	-	-	☉IP为增强型扭矩 顶部磁化		
-10	☉	70	28	-	165	-	10IP	-	-			
-15	☉	70	31	-	174	-	15IP	-	-			
	FH -2	☉	40	20	-	71	2.0	-	-	-	六角	
	-2.5	☉	45	20	-	76	2.5	-	-	-		
	FT -6	☉	35	15	-	65	-	T6	-	-	普通扭矩	
	-7	☉	34	15	-	62	-	T7	-	-		
	-8	☉	40	20	-	74	-	T8	-	-		
	-10	☉	40	20	-	74	-	T10	-	-		
	FT -15	☉	45	25	10	80	-	T15	-	-	普通扭矩	
	FTP -5	☉	35	15	-	65	-	5IP	-	-	☉IP为增强型扭矩	
	-6	☉	34		62	6IP						
	LTW -8SS	☉	43	6	-	-	-	T8	-	-	普通扭矩	
	-10S	☉	62	10	-	-	-	T10	-	-		
	-10SS	☉	47	7	-	-	-	T10	-	-		
	-15S	☉	62	10	-	-	-	T15	-	-		
	-20	☉	58	19	-	-	-	T20	-	-		
	-25	☉	65	20	-	-	-	T25	-	-		

☉: 标准库存



零件

扳手规格·其他零件规格

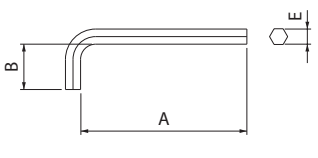
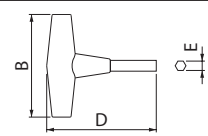
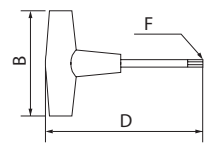
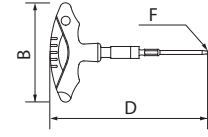
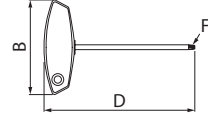
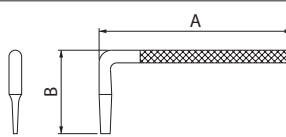
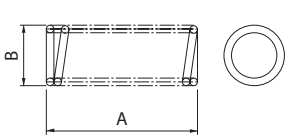
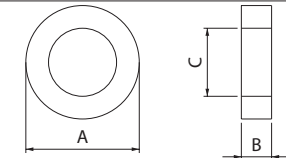
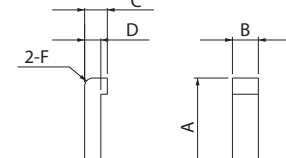
形状	型号	库存	尺寸(mm)						角度		备注
			A	B	C	D	E	F	α	θ	
	LW -1.5	☉	45	14			1.5			六角	
	LW -2	☉	50	16			2.0				
	LW -2.5	☉	56	18			2.5				
	LW -3	☉	63	20			3.0				
	LW -4	☉	70	25			4.0				
	LW -4.5	☉	78	26			4.5				
	LW -5	☉	80	28	-	-	5.0	-	-		
	LW -6	☉	90	32			6.0				
	LW -8	☉	109	36			8.0				
	LW -10	☉	112	40			10.0				
	LW -14	☉	140	56			14.0				
	LW -17	☉	160	63			17.0				
LW -19	☉	180	70			19.0					
	TH -4	☉	-	80	-	83	4.0	-	-	六角	
	TT -15	☉		70		118		T15		普通扭矩	
	TT -25	☉		70		69		T25			
	TT -25L	☉		80		145		T25			
	TT -30	☉		80		110		T30			
	TTC -20	☉			98		130		T20		
	TTC -25	☉							T25		
TTP -20	☉			70		138		20IP		○○IP为增强型扭矩	
	TTP -15-SL	☉		100		172		15IP		○○IP为增强型扭矩	
	TTP -20-SL	☉		100		172		20IP			
	TTW -15	☉		80		125		T15		普通扭矩	
	LTK -5	☉	70	30							
	SP -2D	☉	8.5	5.6						弹簧	
	SP -3D	☉	12.0	7.2							
	SP -5	☉	12.0	6.7							
	SP -5D	☉	12.0	7.2							
	SP -6	☉	12.0	7.7							
	W -6	☉	11.5	1.6	6.4					垫圈	
	W 6-14	☉	11.5	1.4	6.4						
	WB -5	☉	10.0	1.0	5.3					垫圈(黄铜)	
	WB -6	☉	11.5	1.6	6.4						
WB -8	☉	15.5	1.6	8.4							
	WSP -1	☉	15.1	4.0	3.5	2.5		R1.25		间隔片	

☉:标准库存

其他 零件规格

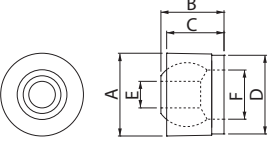
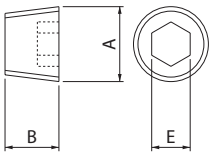
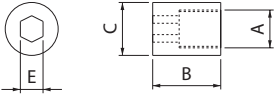
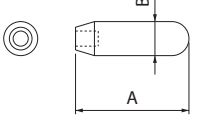
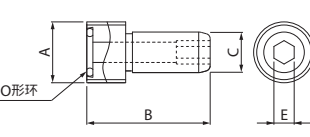
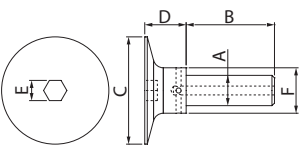
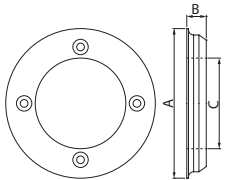
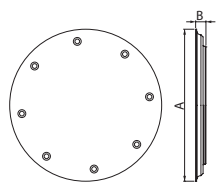
形状	型号	库存	尺寸 (mm)						角度		备注
			A	B	C	D	E	F	α	θ	
	DN 10	☉	6.2	5.1	4.5	5.7	2.6	4.0	-	-	喷嘴
	20	☉	10.1	7.7	7.0	9.6	M4X0.7	6.0	-	-	
	GP -1	☉	PT1/8	7.0	-	-	5.0	-	-	-	插销
	-2	☉	PT1/4	9.0	-	-	6.0	-	-	-	
	WN -1	☉	M5X8	10.0	7.0	-	3.0	-	-	-	螺母
	PC -1	☉	60.0	8.5	-	-	-	-	-	-	冲头
	-2	☉	62.2	10.0	-	-	-	-	-	-	
	CL 63-1	☉	M18X1.0	36.5	12	-	6.0	-	-	-	冷却管
	100-1	☉	M24X1.5	44.0	16.0	-	8.0	-	-	-	
	HH 12X35HC	☉	M12X1.75	35.0	42.5	16.4	8.0	18.0	-	-	冷却孔螺栓
	HF 16X44HC	☉	M16X2.0	30.0	62.5	14.4	12.0	40.0	-	-	
	16X48HC	☉	M16X2.0			18.4	-	-	-	-	
	CC -125-MFAH	☉	87.5	11.4	53.0	-	-	-	-	-	冷却孔盖
	-160-MFAH	☉	122.5	12.4	70.0	-	-	-	-	-	
	CC -200-MFAH	☉	162.5	14.4	-	-	-	-	-	-	冷却孔盖
	-250-MFAH	☉	212.5		-	-	-	-	-	-	
	-315-MFAH	☉	277.5		-	-	-	-	-	-	

☉: 标准库存



外径加工刀杆

型 号	零 件					
	杠杆	紧固螺钉	垫片	金属销	冲头	扳手
PSBN [®] /L 1616H -09	LL-1N	LS-1N	LS-32	LSP-1	PC-1	FH-2.5
PSKN [®] /L 1616H -09	LL-1N	LS-1N	LS-32	LSP-1	PC-1	FH-2.5

外径加工刀杆

型 号	零 件			
	杠杆	紧固螺钉	金属销	扳手
PTGN [®] /L 1212F -11	LL-03N	LS-03N	P-03	FH-2
..... -11	LL-03TN	LS-03SN	P-03S	FH-2.5
PTFN [®] /L 1212F -11	LL-03N	LS-03N	P-03	FH-2
..... -11	LL-03TN	LS-03SN	P-03S	FH-2.5

陶瓷刀具用外径刀杆

型 号	零 件				
	导屑器	压板组	扳手	垫片	垫片紧固螺钉
CCLNR 2525M -16	CB-17	CE-220	LW-4	SP-454	M4X10
CS-N [®] /L -12	CB-11	CE-020	LW-4	SP-141 *(SP-143)	M3X8 *(M3X12)
CSKN [®] /L -12	CB-11	CE-020	LW-4	SP-141 *(SP-143)	M3X8 *(M3X12)
CSYN [®] /L -12	CB-11	CE-020	LW-4	SP-141 *(SP-143)	M3X8 *(M3X12)
CSSN [®] /L -12	CB-11	CE-020	LW-4	SP-141 *(SP-143)	M3X8 *(M3X12)

* 垫片及垫片紧固螺钉：使用SN□□1204刀片时、()内的零件请另行购买。

陶瓷刀具用外径刀杆

型 号	零 件			
	压板组	扳手	垫片	垫片紧固螺钉
CCLN [®] /L -12GX	CE-410	LW-4	SP-441	M3X8
CDHN [®] /L -12GX	CE-410	LW-4	SP-521	M3X8
..... -15GX	CE-430		SP-541	
CDJN [®] /L -12GX	CE-410	LW-4	SP-521	M3X8
..... -15GX	CE-430		SP-541	
CSRN [®] /L -12GX	CE-410	LW-4	SP-141	M3X8
..... -15GX			SP-162	M4X10
CSDNN -12GX	CE-410	LW-4	SP-141	M3X8
..... -15GX			SP-162	M4X10
CSSN [®] /L -12GX	CE-410	LW-4	SP-141	M3X8
..... -15GX			SP-162	M4X10
CS-N [®] /L -12GX	CE-410	LW-4	SP-141	M3X8
..... -15GX			SP-162	M4X10
CSKN [®] /L -12GX	CE-410	LW-4	SP-141	M3X8
..... -15GX			SP-162	M4X10
CSYN [®] /L -12GX	CE-410	LW-4	SP-141	M3X8
..... -15GX			SP-162	M4X10

P

井
輪

整体型CBN刀具用刀杆

型 号	零 件			
	压板组	扳手	垫片	垫片紧固螺钉
CCLN ^{F/L} -09A	CE-030A	LW-4	SP-429	HH3X12
CSRN ^{F/L} 2525M -09A	CE-030A	LW-4	SP-129	HH3X12
			SP-148 *(SP-143)	BH3X12
CSKN ^{F/L} 2525M -09A	CE-030A	LW-4	SP-129	HH3X12
			SP-148 *(SP-143)	BH3X12
CSYN ^{F/L} 2525M -09A	CE-030A	LW-4	SP-129	HH3X12
			SP-148 *(SP-143)	BH3X12
CSDNN -09A	CE-040	LW-4	SP-129	HH3X12
			SP-148 *(SP-143)	BH3X12
CTUN ^{F/L} -11A	CE-030A	LW-4	SP-219	HH3X12

• -12A型刀杆用垫片：使用SN□□1204型的刀片时、()内的零件：SP-143请另行购买。

轴承用外径刀杆

型 号	零 件					
	杠杆	紧固螺钉	垫片	金属销	冲头	扳手
PRGC ^{F/L} -12BE	LL-1CN	LS-1N	LR-12C	LSP-1	PC-1	FH-2.5
	LL-2C	LS-1T	LR-16C	LSP-2	PC-2	FH-2.5
PRGC ^{F/L} -16BF	LL-1CN	LS-1N	LR-12C	LSP-1	PC-1	FH-2.5
	LL-2C	LS-1T	LR-16C	LSP-2	PC-2	FH-2.5

外径(背车)用刀杆

型 号	零 件				
	固定销	锁紧螺钉	紧固螺钉	扳手	
AABSR 0810K -40F	LPA-11	HSB4X8R	-	FH-2	
					1010.. -40F
					1212.. -40F
					1616.. -40F
SABSR -40F	-	-	SB-3080TR	FT-10	
AABWR 0810K -40F	LPA-11	HSB4X8R	-	FH-2	
					1010.. -40F
					1212.. -40F
					1616.. -40F
SABWR -40F	-	-	SB-3080TR	FT-10	
AABWR 0810K -50F	LPA-11	HSB4X8R	-	FH-2	
					1010.. -50F
					1212.. -50F
					1616.. -50F
SABWR -50F	-	-	SB-3080TR	FT-10	

KTKF

型 号	零 件	
	紧固螺钉	扳手
KTKF ^{F/L} -12	SB-4590TRWN	LTW-10S
..... -16		



小零件加工用外径刀杆(背面紧固式)

型 号	零 件			
	固定销	锁紧螺钉	扳手	
ACLCP/L	0810K -06F	LPF-11	HSB4X8/L	FH-2
	1010K -06F			
	1010K -09F			
	1212M -09F			
	1616M -09F			
ADJCP/L	0810K -07F	LPF-11	HSB4X8/L	FH-2
	1010K -07F			
	1010K -11F			
	1212M -11F			
	1616M -11F			
ADNCR	0810K -07F	LPF-11	HSB4X8R	FH-2
	1010K -07F			
	1010K -11F			
	1212M -11F			
	1616M -11F			
AVJBP/L	1010K -11F	LPF-11	HSB4X8/L	FH-2
	1212M -11F			
	1616M -11F			
AVVBR	1010K -11F	LPF-11	HSB4X8R	FH-2
	1212M -11F			
	1616M -11F			

* 锁紧螺钉：右手(R)刀杆适用HSB4X8R、左手(L)刀杆适用HSB4X8L。

小零件加工用外径刀杆(螺钉紧固式)

型 号	零 件		
	紧固螺钉	扳手	
SCLCP/L -06	SB-2570TR	FT-8
 -09	SB-4085TR	FT-15
 -12	SB-5090TR	LTW-20
SCACP/L -06	SB-2570TR	FT-8
 -09	SB-4085TR	FT-15
	1212F -09FF		
SDJCP/L -07F	SB-2570TR	FT-8
 -11F	SB-4085TR	FT-15
SDLCP/L -07FF	SB-2570TR	FT-8
 -11FF	SB-4085TR	FT-15
SDXC/L -07	SB-2570TR	FT-8
 -11	SB-4085TR	FT-15
SDNCP/L -07F	SB-2570TR	FT-8
 -11F	SB-4085TR	FT-15
SDNCN -07	SB-2570TR	FT-8
 -11	SB-4085TR	FT-15
SDLPL/L -07F	SB-2570TR	FT-8
 -11F	SB-4085TR	FT-15
STGC/L -08	SB-2050TR	FT-6
STGP/L -08	SB-2050TR	FT-6
 -11	SB-3080TR	FT-10
 -11	SB-2570TR	FT-8
SVJBP/L -11F	SB-2570TR	FT-8
SVLP/L -08FF	SB-2050TR	FT-6
 -11FF	SB-2570TR	FT-8
 -11F		
SVPP/L -08FF	SB-2050TR	FT-6
 -11FF	SB-2570TR	FT-8
 -11		
SVXP/L -06F	SB-2050TR	FT-6

P

井
脚

小零件加工用外径刀杆(螺钉紧固式)

型 号	零 件		
	紧固螺钉	扳手	插销
SCLCR -09FEJCT	SB-4085TR	FT-15	GP-1
SDJCR -11.JCT	SB-4085TR	FT-15	GP-1
SVJBR -11FEJCT	SB-2570TR	FT-8	GP-1
SVJPR -11FEJCT	SB-2570TR	FT-8	GP-1

小零件加工用外径刀杆(螺钉紧固式)

型 号	零 件				
	紧固螺钉	扳手	垫片	垫片紧固螺钉	扳手
SVPB [®] /L -11	SB-2570TR	FT-8	-	-	-
..... -16N	SB-40125TRN	FT-15	SVN-32N	SS-4N	LW-4
SVVBN -11	SB-2570TR	FT-8	-	-	-
..... -16N	SB-40125TRN	FT-15	SVN-32N	SS-4N	LW-4

小零件加工用外径刀杆(压板紧固方式)

型 号	零 件				
	压板组	扳手	垫片	垫片紧固螺钉	导屑器
CSBP [®] /L -09N	CPS-2P	LW-2.5	-	-	CB-S3220
CSKP [®] /L -09N	CPS-2P	LW-2.5	-	-	CB-S3220
 -12N	CPS-3	LW-3	KPS-42	SP3X8
CSSP [®] /L -09N	CPS-2P	LW-2.5	-	-	CB-S3220
 -12N	CPS-3	LW-3	KPS-42	SP3X8
CSDPN -12N	CPS-3	LW-3	KPS-42	SP3X8	CB-S4220
CTGP [®] /L -11N	CPS-2P	LW-2.5	-	-	CB-T2212
 -16N	CPS-3	LW-3	KPT-32	SP3X8
CTFP [®] /L -11N	CPS-2P	LW-2.5	-	-	CB-T2212
 -16N	CPS-3	LW-3	KPT-32	SP3X8
CTTP [®] /L -11N	CPS-2P	LW-2.5	-	-	CB-T2212
 -16N	CPS-3	LW-3	KPT-32	SP3X8



EZ刀杆PLUS

型 号	零 件	
	紧固螺钉	扳手
S045X-SCLCR03-050EZ	SB-1635TR	FT-6
S060X-SCLCR04-070EZ	SB-2035TR	
C045X-SCLCR03-050EZ	SB-1635TR	FT-6
C060X-SCLCR04-070EZ	SB-2035TR	

双头刀

型 号	零 件	
	紧固螺钉	扳手
STW ^{PI} /L -15	SB-3080TR	LTW-10S
STWSR -15T	SB-3080TR	LTW-10S

系统刀具

型 号	零 件			
	紧固螺钉	扳手	螺钉 (侧固装置)	扳手
SVNR 1010H -12	SB-3080TR	FT-10	HS3X4	LW-1.5
1212K -12			HS3X8	
1616K -12			HS3X12	
2020K -12			HS3X16	
2525M -12				
SVNSR -12-..	SB-3080TR	LTW-10S	HS3X4	LW-1.5
S12F- SVNR 12	SB-3080TR	FT-10	HS3X4	LW-1.5
S14G- SVNR 12			HS3X8	
S16H- SVNR 12				
S19H- SVNR 12				
S19N- SVNR 12				
S20H- SVNR 12				
S25H- SVNR 12				
S25Q- SVNR 12			HS3X12	
S... SVNR 12S	SB-3080TR	FT-10	HS3X4	LW-1.5

系统刀具(S-SVN-XN)

型 号	零 件		
	紧固螺钉	扳手	紧固螺钉
S...- SVNR 12XN	SB-3080TR	FT-10	SP3X4

PSH套筒

型 号	零 件	
	紧固螺钉	扳手
PSH 02.. -..	HS3X4P	LW-1.5
03.. -..		
04.. -..		
05.. -..	HS4X4P	LW-2
06.. -..		
07.. -..		

P

仕
齡

镗刀杆(螺钉紧固式)

型 号	零 件	
	紧固螺钉	扳手
S10H- SCLC [®] /L03-..E	SB-1635TR	FT-6
S10J- SCLC [®] /L04-..E	SB-2035TR	
S08X- SCLC [®] /L06-10E	SB-2545TR	FT-8
S08X- SCLC [®] /L06-10	SB-2545TR	FT-8
C...- SCLC [®] /L03-..	SB-1635TR	FT-6
C...- SCLC [®] /L04-..	SB-2035TR	
C08L- SCLC [®] /L06-10	SB-2545TR	FT-8
A08H- SCLC [®] /L06-10E	SB-2545TR	FT-8
E...- SCLC [®] /L06-..	SB-2545TR	FT-8
S..M- SCLP [®] /L08-..E	SB-35TR	FT-10
S...- SCLP [®] /L09-..E	SB-4TR	FT-15
S..M- SCLP [®] /L08-..	SB-35TR	FT-10
S...- SCLP [®] /L09-..	SB-4TR	FT-15
C10N- SCLP [®] /L08-..	SB-35TR	FT-10
C...- SCLP [®] /L09-..	SB-4TR	FT-15
A..X- SCLP [®] /L08-..E	SB-35TR	FT-10
A...- SCLP [®] /L09-..E	SB-4TR	FT-15
E10N- SCLP [®] /L08-12	SB-35TR	FT-10
E10N- SCLP [®] /L08-12A-..	SB-3060TR	
E...- SCLP [®] /L09-..	SB-4TR	FT-15
S...- SDUC [®] /L07-..E	SB-2560TR	FT-8
S...- SDUC [®] /L11-..E	SB-4085TR	FT-15
S...- SDUC [®] /L07-..	SB-2560TR	FT-8
S...- SDUC [®] /L11-..	SB-4085TR	FT-15
C...- SDUC [®] /L07-..	SB-2560TR	FT-8
C...- SDUC [®] /L11-..	SB-4085TR	FT-15
S...- SDZC [®] /L07-..E	SB-2560TR	FT-8
S...- SDZC [®] /L11-..E	SB-4085TR	FT-15
S...- SDZC [®] /L07-..	SB-2560TR	FT-8
S...- SDZC [®] /L11-..	SB-4085TR	FT-15
C06J- STLB [®] /L06-08A	SB-2035TR	FT-6
E08L- STLP [®] /L08-10A	SB-1TR	
E08L- STLP [®] /L09-10A	SB-2545TR	FT-8
E10N- STLP [®] /L09-..		FT-10
E10N- STLP [®] /L11-..	SB-3060TR	FT-10
S06H- STUB [®] /L06-08E	SB-15TR	FT-6
S08K- STUP [®] /L08-10E	SB-1TR	
S..M- STUP [®] /L09-..E	SB-2TR	FT-8
S...- STUP [®] /L11-..E	SB-3TR	FT-10
S..X- STUP [®] /L16-..E	SB-4TR	FT-15
S06H- STUB [®] /L06-08	SB-15TR	FT-6
S08K- STUP [®] /L08-10	SB-1TR	
S..M- STUP [®] /L09-..	SB-2TR	FT-8
S...- STUP [®] /L11-..	SB-3TR	FT-10
S25X- STUP [®] /L16-32	SB-4TR	FT-15
C10L- STUB [®] /L06-08	SB-15TR	FT-6
C08L- STUP [®] /L08-10	SB-1TR	
C...- STUP [®] /L09-..	SB-2TR	FT-8
C...- STUP [®] /L11-..	SB-3TR	FT-10
C20S- STUP [®] /L16-..	SB-4TR	FT-15
A08H- STUP [®] /L08-10E	SB-1TR	FT-6
A..X- STUP [®] /L09-..E	SB-2TR	FT-8
A...- STUP [®] /L11-..E	SB-3TR	FT-10
A...- STUP [®] /L16-..E	SB-4TR	FT-15
E08L- STUP [®] /L08-10	SB-1TR	FT-6
E...- STUP [®] /L09-..	SB-2TR	FT-8
E...- STUP [®] /L11-..	SB-3TR	FT-10
E20S- STUP [®] /L16-25	SB-4TR	FT-15



镗刀杆(螺钉紧固式)

型号	零件		
	紧固螺钉		扳手
S...- SWUB [®] /L08-..E	SB-2050TR		FT-6
S12M- SWUP [®] /L11-14E	SB-2545TR		FT-8
S...- SWUP [®] /L11-..E	SB-2560TR		
S...- SWUP [®] /L16-..E	SB-4065TR		FT-15
S...- SWUB [®] /L06-...	SB-2040TR		FT-6
S10J- SWUB [®] /L08-...	SB-2035TR		
C...- SWUB [®] /L06-...	SB-2035TR		FT-6
C07K- SWUB [®] /L08-...			
C08L- SWUB [®] /L08-...		SB-2050TR	
C10N- SWUB [®] /L08-...			FT-8
C12Q- SWUP [®] /L11-14(-./.)	SB-2545TR		
C12Q- SWUP [®] /L11-16(-./.)	SB-2560TR		
C16X- SWUP [®] /L11-18(-./.)			
C...- SWUP [®] /L16-..	SB-4065TR		FT-15
E...- SWUB [®] /L08-...	SB-2050TR		FT-6
S16Q- SSKPR09-20	SB-4TR		FT-15
S20R- SSKPR09-25			
S25X- SSKPR12-32	GS-50S		LW-3
S32S- SSKPR12-40	GS-50		
S12M- SYXP [®] /L06-12E	SB-2040TR		FT-6
S16Q- SYXP [®] /L06-16E	SB-2045TR		

镗刀杆(螺钉紧固式)

型号	零件				
	紧固螺钉	扳手	垫片	垫片紧固螺钉	扳手 (垫片紧固螺钉用)
S12M- SVJP [®] /L08-16E	SB-2050TR	FT-6	-	-	-
S...- SVJC [®] /L08-..E		FT-8			
S...- SVJB [®] /L11-..E	SB-2570TR	FT-15	SVN-32N	SS-4N	LW-4
S...- SVJB [®] /L16-..EN	SB-40115TR	FT-15	SVN-32	SB-2050TR	FT-6
S32S- SVJB [®] /L16-40E		FT-15	SVN-32	SB-2050TR	FT-6
S40T- SVJB [®] /L16-50E					
S10M- SVPC [®] /L08-16E	SB-2050TR	FT-6	-	-	-
S...- SVPB [®] /L11-..E	SB-2570TR	FT-8			
S...- SVPB [®] /L16-..EN	SB-40125TRN	FT-15	SVN-32N	SS-4N	LW-4
S25X- SVPB [®] /L16-34E	SB-40115TR	FT-15	SVN-32	SB-2050TR	FT-6
S32S- SVPB [®] /L16-40E		FT-15	SVN-32	SB-2050TR	FT-6
S12M- SVUC [®] /L08-16E	SB-2050TR	FT-6	-	-	-
S...- SVUB [®] /L11-..E	SB-2570TR	FT-8			
S...- SVUB [®] /L16-..EN	SB-40125TRN	FT-15	SVN-32N	SS-4N	LW-4
S25X- SVUB [®] /L16-34E	SB-40115TR	FT-15	SVN-32	SB-2050TR	FT-6
S32S- SVUB [®] /L16-40E		FT-15	SVN-32	SB-2050TR	FT-6
S12M- SVZC [®] /L08-16E	SB-2050TR	FT-6	-	-	-
S...- SVZB [®] /L11-..E	SB-2570TR	FT-8			
S...- SVZB [®] /L16-..EN	SB-40125TRN	FT-15	SVN-32N	SS-4N	LW-4
S25X- SVZB [®] /L16-34E	SB-40115TR	FT-15	SVN-32	SB-2050TR	FT-6
S32S- SVZB [®] /L16-40E		FT-15	SVN-32	SB-2050TR	FT-6

镗刀杆(压板紧固方式)

型号	零件				
	导屑器	压板组	扳手	垫片	垫片紧固螺钉
S12L- CTUP [®] /L09-16	-	CPS-1	FH-2	-	-
S...- CTUP [®] /L11-..	-	CPS-2	FH-2.5	-	-
S25X- CTUP [®] /L16-34	-	CPS-3	LW-3	-	-
S32S- CTUP [®] /L16-43				KPT-32	SP3X10
S40X- CTUP [®] /L16-50					
S32S- CTUC [®] /L16-40	*CB-13/12	CE-320	LW-4	SP-230P	SP3X10
S...- CCLN [®] /L09-..A	-	CE-360S	LW-4	SP-420A	BH3X6
S...- CSKN [®] /L09-..A	-	CE-360S	LW-4	SP-130A	BH3X12
S32S- CSKPR12-43	CPS-3	-	LW-3	KPS-42	SP3X10

*右手(R)刀杆适用CB-13、左手(L)刀杆适用CB-12。

P



社
龄

陶瓷刀具用镗刀杆(压板紧固方式)

型号	零件				
	导屑器	压板组	扳手	垫片	垫片紧固螺钉
S32S- CCLN [®] /L -12-40GX	-	CE-410	LW-4	-	-
S40T- CCLN [®] /L -12-50GX				SP-441P	M3X8
S32S- CDUN [®] /L -12-40GX	-	CE-410	LW-4	-	-
S40T- CDUN [®] /L -12-50GX				SP-521P	M3X8
S32S- CSKN [®] /L -12-40GX	-	CE-410	LW-4	-	-
S40T- CSKN [®] /L -12-50GX				SP-141P	M3X8
S40T- CSKN [®] /L -12-50	¹ CB-13/12	CE-320	LW-4	SP-141P ² (SP-143P)	M3X8 ² (M3X12)

*1 右手(R)刀杆适用CB-13、左手(L)刀杆适用CB-12。
*2 SN□□1204型刀片使用时、()内的零件请另行购买。

轴承用内径刀杆(内径加工)

型号	零件	
	紧固螺钉	扳手
SRCP [®] /L 2020B-12 -A20	SB-4TR	FT-15
2525B-16 -A32	SB-5090TR	LTW-20

整体型刀具用套筒

型号	零件			
	螺钉	扳手		
PH 02 ...	HS3X4	LW-1.5		
			HS4X4	LW-2
	04 ...			
	05 ...			
	06 ...			
07 ...				

KTG

型号	零件	
	紧固螺钉	扳手
KTG [®] /L ... -16	SB-4TR	FT-15
... 22-..	GS-50	LW-3

KN91

型号	零件					
	压板	紧固螺栓	垫圈	弹簧	扳手	
KN91 [®] /L 44 -4	*CE-111/121	BH8X30	W-8	SP-8	LW-5	
						44 -5
						44 -7
	*CE-131/141					

* KN91[®]/L 44-4/5 : 右手(R)刀杆适用CE-111、左手(L)刀杆适用CE-121。
KN91[®]/L 44-7 : 右手(R)刀杆适用CE-131、左手(L)刀杆适用CE-141。

AD 镗刀杆

型号	零件											
	杠杆	紧固螺钉	冲头*	金属销	垫片	紧固螺钉	扳手*	套筒	套筒安装螺栓		套筒扳手	
HA32 PCLN [®] /L 12-40	LL-2K	LS-2P	PC-2K	LSP-3K	LC-4K	-	DTPM-15	AD32U	HH5X20(3根)	HH5X30(1根)	LW-4	
HA40 PCLN [®] /L 12-50								AD40V	HH6X20(3根)	HH6X30(1根)	LW-5	
HA50 PCLN [®] /L 12-63								AD32U	HH5X20(3根)	HH5X30(1根)	LW-4	
HA32 PDUN [®] /L 15-43	LL-3K	LS-3P			LD-4K43 (LD-4K*)			AD40V	HH6X20(3根)	HH6X30(1根)	LW-5	
HA40 PDUN [®] /L 15-50								AD50W	HH6X20(3根)	HH6X30(1根)	LW-5	
HA50 PDUN [®] /L 15-63								AD32U	HH5X20(3根)	HH5X30(1根)	LW-4	
HA32 PTFN [®] /L 16-40	LL-1K	LS-1P	LSP-2K	LT-3K	-	DTPM-10	AD40V	HH6X20(3根)	HH6X30(1根)	LW-5		
HA40 PTFN [®] /L 16-50							AD32U	HH5X20(3根)	HH5X30(1根)	LW-4		
HA50 PTFN [®] /L 16-63							AD50W	HH6X20(3根)	HH6X30(1根)	LW-5		
HA32 SCLC [®] /L 09-40	-	-	-	-	-	-	SB-3580TR	FT-15	AD32U	HH5X20(3根)	HH5X30(1根)	LW-4
HA32 SDUC [®] /L 11-40							SB-3580TR	FT-15	AD32U	HH5X20(3根)	HH5X30(1根)	LW-4

冲头(*PC-2K) : 不属于标准附件, 请另行购买。
一同包装的扳手为L型。
垫片 : 刀杆标准安装LD-4K43。使用DNUU1506刀片时, LD-4K请另行购买。

轴承用内径刀杆(内径R倒角加工)

型号	零件	
	压板组	扳手
CBSN [®] /L ...B-12 -A20	CP-RC [®] /L	LW-5

KTGF

型号	零件	
	紧固螺钉	扳手
KTGF [®] /L -16F	SB-4070TRW	FT-8
KTGF [®] /L -16	SB-4070TRS	FT-10

S-KTGF

型号	零件	
	紧固螺钉	扳手
S.... -KTGFL16	SB-4070TRS	FT-10

KGHS

型号	零件					
	压板	紧固螺栓	垫圈	弹簧	扳手	
KGHS [®] /L -4	CGH-1L/R	HH6X25	W-6	SP-6	LW-5	
					 -5
					 -7
	CGH-2L/R					

• 压板 : KGHS[®]/L 右手(R)刀杆适用CGH-○L、左手(L)刀杆适用CGH-○R。



件
驗

KGA

型号	零件			
	压板	紧固螺栓	弹簧	扳手
KGA ^{R/L} -3	CGA-3 ^{R/L}	HH6X20	SP-6	LW-5
.... -4	CGA-4 ^{R/L}			
.... -5	CGA-5 ^{R/L}			

· 压板：右手(R)刀杆适用CGA-○R,左手(L)刀杆适用CGA-○L。

KGD^{R/L}....-S

型号	零件		
	紧固螺栓 (刀片紧固用)	安装螺栓 (刀板用)	扳手
KGD ^{R/L}-S	BH6X10TR	SB-60120TR	LTW-25

KGD-JCT (自动车床用)

型号	零件		
	紧固螺钉	扳手	插销
KGD ^{R/L} -... JCT	SB-40120TR	LTW-15S	GP-1

KGDF^{R/L}....-S

型号	零件		
	紧固螺栓 (刀片紧固用)	安装螺栓 (刀板用)	扳手
KGDF ^{R/L}-S	BH6X10TR	SB-60120TR	LTW-25

KGM

型号	零件	
	紧固螺钉	扳手
KGM ^{R/L} 1212H -3	SB-5TR	LTW-20
1616H -3	HH5X16	LW-4
2020K -3		
2525M -3		
KGM ^{R/L} 2020K -4	HH5X16	LW-4
2525M -4	HH5X25	
KGM ^{R/L} 2020K -5	HH5X16	LW-4
2525M -5	HH5X25	
3232P -5		
KGM ^{R/L} 2525M -8	HH6X25	LW-5
3232P -8		

KGM-T

型号	零件	
	紧固螺钉	扳手
KGM ^{R/L} 2012K-2T17	SB-5TR	LTW-20
2020K-2T17	HH5X16	LW-4
2525M-2T17	HH5X25	
KGM ^{R/L} 1616H-3T20	HH5X16	LW-4
2012K-3T20	SB-5TR	LTW-20
2020K-3T20	HH5X16	LW-4
2525M-3T20	HH5X25	
KGM ^{R/L} 2020K-4T20	HH5X16	LW-4
2525M-4T20	HH5X25	
2525M-4T25		
KGM ^{R/L} 2525M-5T25	HH5X25	LW-4
3232P-5T25		
KGM ^{R/L} 2525M-6T30	HH5X25	LW-4

KGM (自动车床用)

型号	零件	
	紧固螺钉	扳手
KGM ^{R/L} 0810K -...	SE-40120TR	LTW-15S
1010.. -...		
1212.. -1.5-...		
1212.. -2-...		
1212.. -2.5-...		
1616.. -2-...		
KGM ^{R/L} 1616.. -2.5-...	SE-50125TR	LTW-20
1616.. -3-...		

KGMM / KGMS

型号	零件	
	紧固螺钉	扳手
KGMM ^{R/L} 1212H-3	SB-5TR	LTW-20
1616H-3	HH5X16	LW-4
2020K-3		
2525M-3		
KGMS ^{R/L} 1212H-3	SB-5TR	LTW-20
1616H-3	GS-50	LW-3
2020K-3	HH5X16	LW-4
2525M-3	HH5X25	

P



寸
齡

KGMU

型号	零件		
	紧固螺栓	扳手	
KGMU [®] /L	2020K	HH5X16	LW-4
	2525M	HH5X25	

KIGH

型号	零件					
	压板	紧固螺栓	垫圈	弹簧	扳手	
KIGHR-4	CGH-1L	HH6X25	W-6	SP-6	LW-5
-5					
-7	CGH-2L				

KIGM-V

型号	零件		
	紧固螺钉	扳手	
KIGM [®] /L	2016B-3V	GS-50	LW-3
	2520B-3V		
	3225B-3V	SB-5TR	LTW-20
	3225B-4V	SB-5TR	LTW-20
	4032B-4V		

GFVS-AA / GFVT-AA

型号	零件		
	压板组	扳手	
GFVS [®] /L -08AA	CPS-5V	FT-15
GFVT [®] /L -08AA	CPS-5V	FT-15

GIFV

型号	零件		
	压板组	扳手	
GIFV [®] /L	5032B-502B	CPS-6V	LW-3

KTKF-JCT

型号	零件			
	紧固螺钉	扳手	插销	
KTKF [®] /L - ... JCT	SB-4590TRWN	FT-10	GP-1

KTKFS (对应副主轴)

型号	零件		
	紧固螺钉	扳手	
KTKFS [®] /L - ...	SB-4050TRN	LTW-10S

KTKH-S

型号	零件	
	拆卸扳手	
KTKH [®] /L - ...S	LTK-5

KTKH-B

型号	零件		
	紧固螺钉	扳手	
KTKH [®] /L	0808K - ...B	SE-40120TR	FT-15
	1010K - ...B		
	1212M - ...B		
	1414M - ...B		
	1616M - ...B	SE-50125TR	LTW-20

KTTX

型号	零件		
	紧固螺钉	扳手	
KTTXR -16F	SB-4070TRW	FT-8



DRS

型号	零件	
	紧固螺钉	扳手
S20 -DRS 10...	SB-2080TR	FT-6
-DRS 11...	SB-2290TR	FT-6
-DRS 12...	SB-25100TR	DT-7

DRX

型号	零件	
	紧固螺钉	扳手
S.. -DRX -. -03	SB-2042TRG	DTM-6
-DRX -. -04	SB-2042TRG	DTM-6
-DRX -. -05	SB-2045TR	DTM-6
-DRX -. -06	SB-2250TR	DTM-7
-DRX -. -07	SB-2570TR	DTM-8
-DRX -. -09	SB-3080TR	DTM-10
-DRX -. -11	SB-4085TR	DTM-15
-DRX -. -14	SB-5090TR	DT-20
-DRX -. -17	SB-60120TR	DT-25

P



件
号







MFPN45 (面铣刀)

型号	零件		
	紧固螺钉	扳手	防止高温烧蚀剂
MFPN 45100R-10T-M ? 45200R-20T-M	SB-40140TRN	DTM-15	P-37

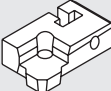
MOF45

型号	零件		
	紧固螺钉	扳手	锥柄安装用螺栓
MOF 45080R-05-6T 45100R-05-.T ? 45200R-05-..T	SB-4082TPR	DTP-15	HH12X35
MOF 45080R-07-5T 45100R-07-.T ? 45200R-07-..T	SB-50120TRS	DTP-15	HH12X35
MOF 45040R-05-3T-M 45050R-05-4T-M 45063R-05-5T-M 45080R-05-6T-M 45100R-05-.T-M ? 45200R-05-..T-M	SB-4082TPR	DTP-15	HH8X25 HH10X30 HH12X35
MOF 45063R-07-4T-M 45080R-07-5T-M 45100R-07-.T-M ? 45200R-07-..T-M	SB-50120TRS	DTP-15	HH10X30S HH12X35



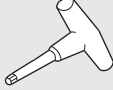

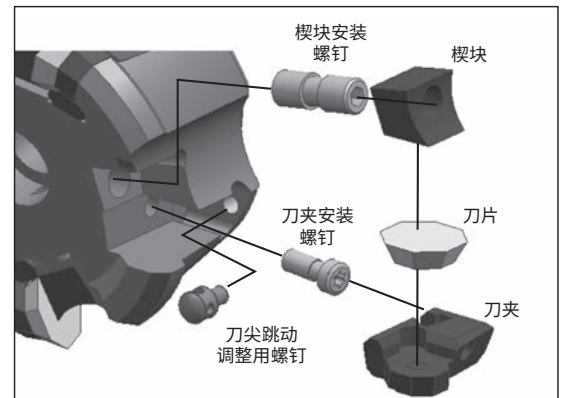
MOFX45

型号	刀夹	刀夹安装螺钉	楔块	楔块安装螺钉
MOFX45...				
MOFX45...	LOF07R	SH-50150TR	WOF07R	W8X21
型号	刀尖跳动调整用螺钉	扳手 (楔块用)	扳手 (刀夹用)	
MOFX45...				
MOFX45...	AJ-412	TH-4	TTC-20	



件
驗

MSE45 (面铣刀)

型号	(1) 紧固螺钉	(2) 扳手	(3) 垫片	(4) 垫片紧固螺钉	(5) 扳手
	MSE 45040R-.T-M 45050R-.T-M				
MSE 45080R-.T ? 45200R-..T	CP8X15TL (左螺纹)	TTC-25	MSE-4245S	SP4X9	LW-2 (垫片固定螺钉用)
MSE 45063R-.T-M ? 45200R-..T-M	CP8X23TL (左螺纹)				

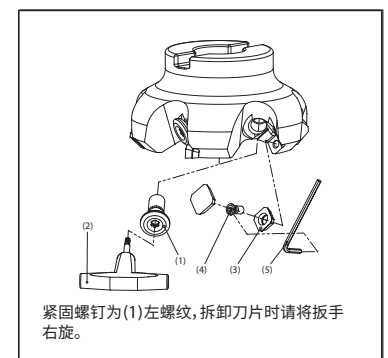

- MSE45040R-.T-M 附带锥柄安装用螺栓 (SP8X35)。
- MSE45050R-.T-M和MSE45063R-.T-M 附带锥柄安装用螺栓 (HH10X30S)。
- MSE45080R-.T和MSE45080R-.T-M附带锥柄安装用螺栓 (HH12X35)。

MSE45 (立铣刀)

型 号	零 件			
	压板组	扳手	垫片	垫片紧固螺钉
MSE 4550	CPS-6M	LW-3	MSE-4245	SP3X8
4563				
4580-32				

MSE45-SF (面铣刀)

型 号	(1) 刀夹	(2) 压板	(3) 压板	(4) 紧固螺钉	(5) 调整螺钉	(6) T型扳手
MSE 45..R-T-SF	LSE-445SR	C43R (刀片用)	C44R (刀夹用)	W6X17	SV-60136TR	TTC-20
45..R-T-M-SF						

- MSE45063R-4T-M-SF附带锥柄安装用螺栓(HH10X30S)。
- MSE45080R-5T-M-SF附带锥柄安装用螺栓(HH12X35)。

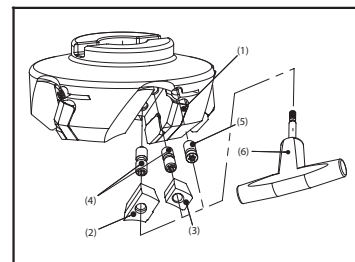

MSD45 (面铣刀)

型 号	(1) 刀夹	(2) 刀夹紧固螺钉	(3) 压板	(4) 紧固螺钉	T型扳手
MSD 45...R	LSD-445R	HH4X16	C20R	TH8X15	TH-4

- MSD4580R附带锥柄安装用螺栓(HH12X35)。

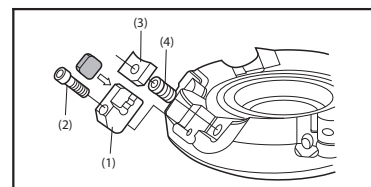

MSD45 (立铣刀)

型 号	零 件			
	压板组	扳手	垫片	垫片紧固螺钉
MSD 4550	CPS-6M	LW-3	MSD-42	SP3X8
4563				
4580-32				

MSO45 (面铣刀)

型 号	(1) 刀夹	(2) 刀夹紧固螺钉	(3) 压板	(4) 紧固螺钉	T型扳手
MSO 45...R	LSO-445R	HH4X16	CH-20R	TH8X15	TH-4

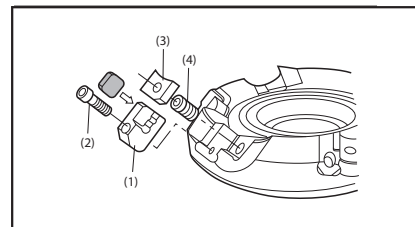

MSO45-S (立铣刀)

型 号	零 件				
	垫片	垫片紧固螺钉	压板	紧固螺钉	T型扳手
MSO 45..S	MSO-4T245	SP3X6	CH-20R	TH8X15	TH-4

MSO45-09 (面铣刀)

型 号	零 件	
	紧固螺钉	扳手
MSO 45...R-09	SB-3060TR	DT-10

MSO45-S-09 (立铣刀)

型 号	零 件	
	紧固螺钉	扳手
MSO 45..-S32-09	SB-3060TR	DT-10

MSP15 / MSE15 (立铣刀)

型号	压板组	扳手	垫片	垫片紧固螺钉
MSP 15..	CPS-6M	LW-3	MSP-42	SP3X8
MSE 15..	CPS-6M	LW-3	MSE-4215	SP3X8

MSP15 (面铣刀)

型号	(1) 刀夹	(2) 刀夹紧固螺钉	(3) 压板	(4) 紧固螺钉	T型扳手
MSP 15...R	LSP-415R	HH4X16	C25R	TH8X15	TH-4

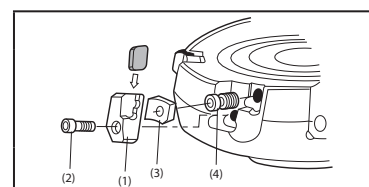

• MSP1580R 附带锥柄安装螺栓 (HH12X35)。

MEC (面铣刀)

型号	零件	
	紧固螺钉	扳手
MEC ...R-11...T(-M)	SB-255TRG	DTM-8
MEC ...R-17...T(-M)	SB-4070TRN	DTM-15

MEC (立铣刀)

型号	零件	
	紧固螺钉	扳手
MEC ...W..-1103(-H)	SB-2545TR	DTM-8
MEC ...W..-11T3(-H)	SB-2555TRG	DTM-8
MEC ...W..-1704-H	SB-4070TRN	DTM-15

MECX (面铣刀)

型号	零件	
	紧固螺钉	扳手
MECX 050R-07-12T-M 063R-07-14T-M	SB-2042TRG	DTM-6

MECX (立铣刀)

型号	零件	
	紧固螺钉	扳手
MECX 32-S32-07-6T 33-S32-200-07-6T	SB-2042TRG	DTM-6

MTE90-SF

型号	刀夹	压板	压板	紧固螺钉	调整螺钉	T型扳手
MTE 90...SF	LTE-490SR	C91R (刀片用)	C92R (刀夹用)	W8X16	SV-60136R	TTC-25

MTE90 (面铣刀)

型号	(1) 刀夹	(2) 刀夹紧固螺钉	(3) 压板	(4) 紧固螺钉	T型扳手
MTE 90...R	LTE-490R	HH4X16	C17R	W8X18	TH-4

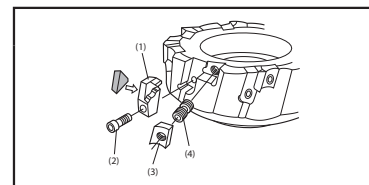

MTE90 (立铣刀)

型号	零件				
	压板	双头螺钉	扳手	垫片	垫片紧固螺钉
MTE 9050 9063 9080-32	CP-8TE	W8X18	LW-4	MTE-42	SP3X8

P







零件

MFWN (面铣刀)

型号	零件		
	紧固螺钉	扳手	防止高温烧结剂
MFWN 90100R-9T-M ? 90250R-18T-M	SB-40140TRN	DTM-15	P-37

MSO90 (面铣刀)

型号	(1) 紧固螺钉	(2) 扳手	(3) 垫片	(4) 垫片紧固螺钉	(5) 扳手
	MSO 90...R-15-.T MSO 90...R-15-.T-M				
	SB-45130TR	DTP-20	MSO-5200	SPW-6045	LW-4.5 (垫片固定螺钉用)

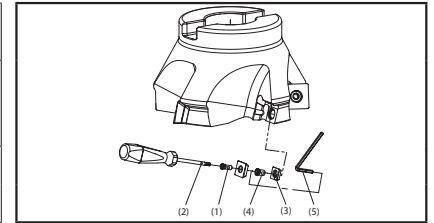

• MSO90080R-15-.T与MSO90080R-15-.T-M附带锥柄安装用螺栓(HH12X35)。
• MSO90063R-15-.T-M附带锥柄安装用螺栓(HH10X30S)。

MSO90-S (立铣刀)

型号	零件	
	紧固螺钉	扳手
MSO 90...S32-09 90...S32-15	SB-3080TR SB-5085TR	DT-10 DT-20

MSO90-09 (面铣刀)

型号	零件	
	紧固螺钉	扳手
MSO 90...R-09	SB-3080TR	DT-10

MEA / MEB

型号	零件	
	紧固螺钉	扳手
MEA .. -S.(-...)	SB-2560TR	DT-8
MEB .. -S..	SB-4085TR	DT-15

DMC

型号	零件	
	紧固螺钉	扳手
DMC 8.. (-S..)	SB-2545TR	FT-8
DMC 0..	SB-3060TR	FT-10

MTP

型号	零件				
	紧固块	双头螺钉	扳手	垫片	垫片紧固螺钉
MTP 90..	CP-8W	W8X18	LW-4	KPT-42	SP3X8

MTPS / MTES

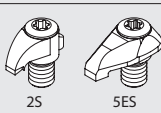
型号	压板组	扳手
		 2S 5ES
MTPS ...	CPS-2S	FT-15
MTES ...	CPS-5ES	

MEAL

型号	零件	
	紧固螺钉	扳手
MEAL .. -S..	SB-5085TR	DT-20

MRP-S (立铣刀)

型号	零件	
	紧固螺钉	扳手
MRP ...-S.. -08(-...)	SB-3060TR	DT-10
...-S.. -10-.T(-...)	SB-3080TR	DT-10
...-S.. -12(-.T)(-...)	SB-4085TR	DT-15
050-S42 -12(-300)	SB-40115TR	
...-S.. -16(-...)	SB-50120TR	DT-20

P



仕
驗

MRP (面铣刀)

型 号	零 件	
	紧固螺钉	扳手
MRP ...R -10-.T	SB-3080TR	DT-10
MRP 050R -12 063R -12 080R -12 080R -12-7T	SB-40115TR	DT-15
	SB-4085TR	
MRP ...R -16(-.T)	SB-50120TR	DT-20
MRP ...R -20	SB-60120TR	DT-25

MHD (立铣刀)

型 号	零 件						
	紧固螺钉	扳手	紧固螺栓		扳手		
			前段刀1个	前段刀2个			
MHD 32-S32 -SA 40-S32 -SA 40-S42 -SA 50-S42 -SA	SB-2560TR	DT-8	-	HH8X50	LW-6		
	SB-3080TR	DT-10		HH8X65			
				HH12X65		LW-10	
MHD 40-S42 -SB 50-S42 -SB	SB-3080TR	DT-10	HH8X40	-	LW-6		
			HH12X40		LW-10		
MHD 205-S20 -C 25-S25 -C 32-S32 -C 40-S42 -C 50-S42 -C	SB-2560TR	DT-8	-	-	-		
						SB-3080TR	DT-10
MHD 32-S32 -A 40-S32 -A 40-S42 -A 50-S42 -A	SB-2560TR	DT-8	HH8X35	HH8X50	LW-6		
	SB-3080TR	DT-10	HH8X40	HH8X65			
			HH12X40	HH12X65		LW-10	
MHD 32-S32 -A-130 40-S32 -A-150 50-S42 -A-150	SB-2560TR	DT-8	HH8X35	HH8X50	LW-6		
	SB-3080TR	DT-10	HH8X40	HH8X65			
			HH12X40	HH12X65		LW-10	
MHD 40-S42 -B 50-S42 -B	SB-3080TR	DT-10	HH8X40	-	LW-6		
			HH12X40		LW-10		
MHD 32 -F 40 -F 50 -F	SB-2560TR	DT-8	-	-	-		
	SB-3080TR	DT-10					

MHD (面铣刀·锥柄一体式)

型 号	零 件					
	紧固螺钉	扳手	紧固螺栓	扳手		
MHD 63-FMA -SA 80-FMA -SA 100-FMA -SA	SB-3080TR	DT-10	HH16X90	LW-14		
			HH20X110	LW-17		
			HH24X110	LW-19		
HH16X90			LW-14			
HH20X110			LW-17			
HH24X110			LW-19			
MHD 63-BT50 -SA 80-BT50 -SA 100-BT50 -SA			SB-3080TR	DT-10	HH16X65	LW-14
					HH20X90	LW-17
					HH24X90	LW-19
MHD 63-BT50 -A 80-BT50 -A 100-BT50 -A			SB-3080TR	DT-10	HH16X65	LW-14
	HH20X90	LW-17				
	HH24X90	LW-19				
MHD 63 -F 80 -F 100 -F			-	-		



零件

MHD (圆角型)

型号	零件								
	紧固螺钉		扳手		紧固螺栓		扳手		
	顶刃用	中间刃用	顶刃用	中间刃用	前段刀1个	前段刀2个			
MHD	32-S32	-4RSA	SB-2560TR	SB-2560TR	DT-8	DT-8	-	HH8X50	LW-6
	40-S32	-5RSA	SB-3080TR	SB-3080TR	DT-10	DT-10		HH8X55	
	40-S42	-5RSA					DT-15	HH12X55	LW-10
	50-S42	-6RSA	SB-4085TR	DT-8	DT-8	DT-8	HH8X50	LW-6	
MHD	32-S32	-A	SB-2560TR		DT-8		-	HH8X50	LW-6
	40-S32	-A	SB-3080TR		DT-10			HH8X65	
	40-S42	-A						HH12X65	LW-10
	50-S42	-A	DT-8	DT-8	DT-8	DT-8		DT-8	DT-8
MHD	32	-F	SB-2560TR		DT-8		-	-	-
	40	-F	SB-3080TR		DT-10				
	50	-F							
MHD	32	-4RF	SB-2560TR	SB-2560TR	DT-8	DT-8	-	-	-
	40	-5RF	SB-3080TR	SB-3080TR	DT-10	DT-10			
	50	-6RF	SB-4085TR	SB-3080TR	DT-15	DT-10			

MEZ

型号	零件		
	紧固螺钉	扳手	
MEZ	16-S16....	SB-2040TRG	DTM-6
	20-S20....	SB-2555TRG	DT-8
	25-S25....	SB-3070TRG	DT-10
	32-S32....	SB-4070TRG	DT-15
	40-S32....	SB-3070TRG	DT-10
	50-S42....	SB-4070TRG	DT-15

MGI

型号	零件		
	压板组	扳手	
MGI-1C	CPS-6F	LW-3

MVG

型号	零件		
	压板组	扳手	
MVG	CPS-6V	LW-3

毛坯工具

型号	零件	
	冷却管	
T63H	-BL...-...	CL63-1





法兰刀杆

型号	零件							
	螺钉	扳手	安装螺栓	扳手	调整螺钉	扳手		
SF22F	-SCLCL09	-40P	SB-4085TR	FT-15	HH5X30	LW-4	HS3X4	LW-1.5
	-SDUCL11	-40P	SB-4085TR	FT-15	HH5X30	LW-4	HS3X4	LW-1.5
	-SVUBL11	-40P	SB-2570TR	FT-8	HH5X30	LW-4	HS3X4	LW-1.5
	-KTGFL16	-40P	SB-4070TRS	FT-10	HH5X30	LW-4	HS3X4	LW-1.5
	-KTTXL16	-40P	SB-4070TRW	FT-8	HH5X30	LW-4	HS3X4	LW-1.5

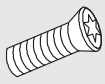
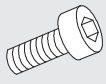

法兰刀杆(套筒型)

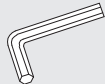
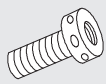
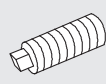
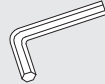
型号	零件							
	安装螺栓	扳手	调整螺钉	扳手	紧固螺钉 (刀杆紧固用)	扳手		
SF22F	-SH1..	-40P	HH5X30	LW-4	HS3X4	LW-1.5	HS6X4P	LW-3

HS-MFAL

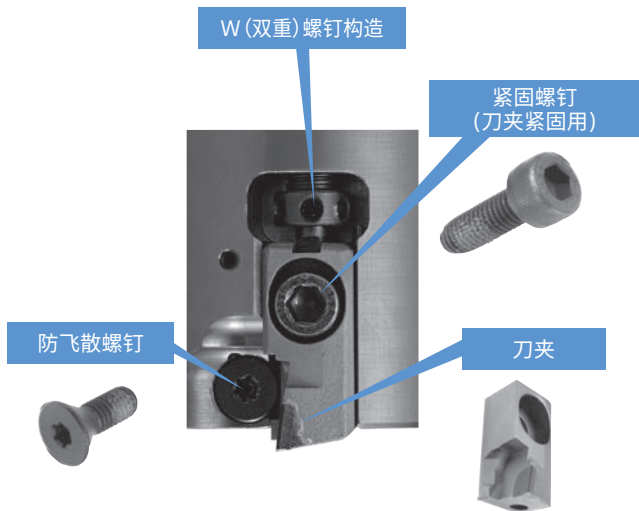
型号	零件								
	(1)防飞散螺钉	(2)紧固螺钉	(3)扳手	(4)扳手	(5)调整螺钉A	(6)调整螺钉B	(7)扳手	(8)调整扳手	(9)平衡螺钉
HS-MFAL 063R.... 080R.... ? 250R....									
	SB-50137K	HH6X16A HH6X18A 刀夹紧固用	TTC-20	LW-5	AJ-816	AJ-519	LW-2.5	AW-3L	HS6X8T

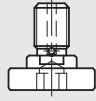

型号	零件		
	带冷却孔锥柄 安装用螺栓(标准附属品)	带冷却孔锥柄 安装用螺栓(另售)	冷却孔盖(另售)
			
HS-MFAL	080R-6T-SF	HH12X35HK	-
	100R-6T-SF	-	HF16X40HA
	125R-8T-SF	-	HF20X53HA
	160R-12T-SF	-	HF24X60HA
	200R-14T-SF	-	-
	250R-18T-SF	-	CC-200
			CC-250
HS-MFAL	063R-4T-M-SF	HH10X35HK	-
	080R-6T-M-SF	HH12X35HK	-
	100R-6T-M-SF	-	HF16X40HA
	125R-8T-M-SF	-	HF20X53HA
	160R-12T-M-SF	-	-
	200R-14T-M-SF	-	CC-200
	250R-18T-M-SF	-	CC-250

注) HS-MFAL100R~250R使用内冷时、请使用另售的带冷却孔锥柄安装用螺栓(HF...HA)或冷却孔盖(CC...)

